

FUJITSU

USER'S MANUAL

*Print Partner*TM

14ADV

14 ppm page printer

Notice to American Users**Federal Communications Commission
Radio Frequency Interference Statement**

Notice: This equipment has been tested and found to comply with the limits for a Class B digital device, pursuant to Part 15 of the FCC Rules. These limits are designed to provide reasonable protection against harmful interference in a residential installation. This equipment generates, uses, and can radiate radio frequency energy and, if not installed and used in accordance with the instructions, may cause harmful interference to radio communications. However, there is no guarantee that interference will not occur in a particular installation. If this equipment does cause harmful interference to radio or television reception, which can be determined by turning the equipment off and on, the user is encouraged to try to correct the interference by one or more of the following measures:

- Reorient or relocate the receiving antenna.
- Increase the separation between the equipment and receiver.
- Connect the equipment into an outlet on a circuit different from that to which the receiver is connected.
- Consult the dealer or an experienced radio / TV technician for help.

FCC warning: Changes or modifications not expressly approved by the party responsible for compliance could void the user's authority to operate the equipment.

Notes

- Testing of this equipment was performed on model number M3878SA14AV.
- The use of a non-shielded interface cable with the referenced device is prohibited. The length of the parallel interface cable must be 3 meters (10 feet) or less. The length of the serial interface cable must be 15 meters (50 feet) or less.
- The length of the power cord must be 3 meters (10 feet) or less.

Laser Safety Information

This printer has been designed and manufactured according to FDA regulations "title 21, CFR, chapter I, subchapter J, based on the Radiation Control for Health and Safety Act of 1968", and is classified as class 1 laser product.

Warning: Use of controls, adjustments or performance of procedures other than those specified herein may result in hazardous radiation exposure.

Notice to Canadian Users

This class B digital apparatus meets all requirements of the Canadian Interference-Causing Equipment Regulations.

Cet appareil numérique de la Classe B respecte toutes les exigences du Règlement sur le matériel brouilleur du Canada.

Notice to German Users**Bescheinigung des Herstellers/Importeurs**

Hiermit wird bescheinigt, daß der M3878SA14AV der Maschinenlärminformationsverordnung 3. GSGV, 18.01.1991 entspricht. Der höchste Schalldruckpegel beträgt 70 dB (A) oder weniger gemäß EN27779-1991.

In case that the interface board, Ethernet C, is installed, this equipment complies with EMI regulations as follows:

Notice to American Users

**Federal Communications Commission
Radio Frequency Interference Statement**

Notice: This equipment has been tested and found to comply with the limits for a Class A digital device, pursuant to Part 15 of the FCC Rules. These limits are designed to provide reasonable protection against harmful interference when the equipment is operated in a commercial environment. This equipment generates, uses, and can radiate radio frequency energy and, if not installed and used in accordance with the instruction manual, may cause harmful interference to radio communications. Operation of this equipment in a residential area is likely to cause harmful interference in which case the user will be required to correct the interference at his own expense.

FCC warning: Changes or modifications not expressly approved by the party responsible for compliance could void the user's authority to operate the equipment.

Notes

- Testing of this equipment was performed on model number M3878SA14AV.
- The use of a non-shielded interface cable with the referenced device is prohibited. The length of the parallel interface cable must be 3 meters (10 feet) or less. The length of the Ethernet interface cable must be 100 meters (328 feet) or less for type 10BASE-2 and 185 meters (607 feet) or less for type 10BASE-T.
- The length of the power cord must be 3 meters (10 feet) or less.

Laser Safety Information

This printer has been designed and manufactured according to FDA regulations "title 21, CFR, chapter I, subchapter J, based on the Radiation Control for Health and Safety Act of 1968", and is classified as class 1 laser product.

Warning: Use of controls, adjustments or performance of procedures other than those specified herein may result in hazardous radiation exposure.

Notice to Canadian Users

This class A digital apparatus meets all requirements of the Canadian Interference-Causing Equipment Regulations.

Cet appareil numérique de la Classe A respecte toutes les exigences du Règlement sur le matériel brouilleur du Canada.

Notice to German Users

Bescheinigung des Herstellers/Importeurs

Hiermit wird bescheinigt, daß der M3878SA14AV der Maschinenlärminformationsverordnung 3. GSGV, 18.01.1991 entspricht: Der höchste Schalldruckpegel beträgt 70 dB (A) oder weniger gemäß EN27779-1991.

Notice to European and Oceanian Users

Warning: This is a product which meets Class A of EN55022 and AS/NZS3548. In a domestic environment this product may cause radio interference in which case the user may be required to take adequate measures.



As an International ENERGY STARSM Partner, Fujitsu Limited has determined that this product meets the International ENERGY STAR Office Equipment Program for energy efficiency.

The International ENERGY STAR Office Equipment Program is an international program that promotes energy saving through the use of computers and other office equipments. The program backs the development and dissemination of products with functions that effectively reduce energy consumption. It is an open system in which business proprietors can participate voluntarily. The targeted products are office equipment such as computers, displays, printers, facsimiles, and copiers. Their standards and logos are uniform among participating nations.

CE Declaration

This product sold in Europe conforms to the standards in accordance with EC Directives. The copy of "Declaration of Conformity" is attached in the next page.



DECLARATION OF CONFORMITY

(according to EN45014)

according to Electromagnetic Compatibility Directive 89/336/EEC and Low Voltage Directive 73/23/EEC, Annex III B.

FUJITSU LIMITED, 1405 Ohmaru Inagi-shi, Tokyo 206, Japan.

declares, in sole responsibility, that the following products

Product Type : L A S E R P R I N T E R
Model Number : M 3 8 7 8 S B # # A D V
(## stands for any number 00 to 99)

including the following options,

Interface boards : CA04040-C801, C802, C826, C83*, C87*
Memory expansion cards : CA02417-C851, C852, C854, C858
CA02758-C856, CA04040-C853
Emulation Cards : CA04040-C82*
Paper Feeders : CA02758-C75*
Multi function Feeder : CA02758-0880
Duplex unit : CA04040-C75*
(* stands for any number 0 to 9)

Approval ID Number : S 9551798

referred to in this declaration, conforms with the following directives and standards :

Electromagnetic Compatibility Directive 89/336/EEC, 92/31/EEC, 93/68/EEC
Low Voltage Directive 73/23/EEC, 93/68/EEC

EN55022 1994+A1 Class A for 10BASE-T and 10BASE-2 interfaces
EN55022 1994+A1 Class B for Centronics, RS232C and LocalTalk interfaces
EN50082-1 1992 (IEC801-2 1984/1991, IEC801-3 1984, ENV50140 1993, IEC801-4 1988)
EN60555-2 1987, EN60555-3 1987, EN61000-3-3 1995
EN60950 1992+A1+A2
EN60825 09.91

Importer / Distributor in EU :

Fujitsu Europe Ltd.,
2, Longwalk Road, Stockley Park, Uxbridge, Middlesex UB11 1AB, England, U.K.

Japan, December 24, 1996.

Reference No.: CE-4582-96111

Kazuyasu Sato
Kazuyasu Sato
Director, Customer Satisfaction Eng. Dept.
Compact Printer Division

The contents of this manual may be revised without prior notice and without obligation to incorporate changes and improvements into units already shipped.

Fujitsu has made every effort to ensure that the information included here is complete and accurate at the time of publication. The company assumes no liability for errors and omissions.

Copyright © 1997 Fujitsu Limited

Printed in Japan. All rights reserved. No part of this manual may be reproduced or translated, stored in a database or retrieval system, or transmitted, in any form or by any means, electronic, mechanical, photocopying, recording, or otherwise, without the prior written permission of Fujitsu Limited.

C145-E172-01EN, January 1997

Trademark Acknowledgment

Fujitsu is a registered trademark of Fujitsu Limited. The following companies own the other trademarks used in this manual:

Adobe Systems, Inc.: PostScript	Centronics Data Computer Corporation: Centronics
Agfa Division of Miles Inc.: Albertus,	Hewlett-Packard Corporation: Hewlett-Packard, LaserJet, LaserJet 4, PCL
Antique Olive, Arial, CG Omega, CG	International Business Machines Corporation: IBM, IBM PC/AT, IBM PS/2, PC-DOS
Times, Clarendon Condensed, Coronet,	Microsoft Corporation: Microsoft, MS-DOS, Windows
Courier, Garamond, Letter Gothic,	Lexmark: MarkVision
Marigold, Symbol, Times New Roman,	Miles, Inc.: Intellifont
Univers, Univers Condensed, Wingdings	Novell, Inc.: Netware
Apple Computer, Inc.: AppleTalk,	Xerox Corporation: 4024, Ethernet, Xerox
LocalTalk, Macintosh, TrueType	
AT&T: UNIX	

Precautions

Read this section and remember these instructions to ensure your safety and your printer's correct performance. Follow the cautions and notices labeled on the printer or marked with icons in the manual. Save this manual for future reference.

- Use only the power cord furnished with the printer and a properly grounded outlet. Do not use an extension power cord.
- Confirm that the rated voltage of your printer matches the voltage of your power outlet. The maximum wattage of the printer is 600 watts.
- Turn off the printer and disconnect the power cord before beginning maintenance operations.
- Disconnect the power cord from the outlet whenever you are not using the printer for an extended period of time.
- Disconnect the power cord from the outlet whenever thunder storms are nearby. Leaving the power cord connected may allow damage to the printer or other property.
- Do not put the printer in direct sunlight, near a heater, or near water. Leave adequate space around the printer.
- Do not touch any connector contacts and corona wires. This could cause electrostatic damage to the printer.
- Do not touch the heat roller and motors if you have been printing recently. These parts may be hot.
- Do not touch or scratch the green drum surface, and do not expose it to light for more than three minutes.
- Use only a shielded interface cable of 3 meters (10 feet) or less for the parallel interface, 15 meters (50 feet) or less for the serial interface, 100 meters (328 feet) or less for Ethernet interface 10BASE-T connection, and 185 meters (607 feet) or less for the Ethernet interface 10BASE-2 connection.
- Be sure the printer is turned off before connecting the interface.
- Do not turn the printer off while it is printing.
- Do not disassemble or remove any components unless instructed in the maintenance procedures.
- Keep the print unit upright when removing or installing it.
- Do not apply excessive pressure on the corona wire when cleaning it.
- Do not use alcohol or other cleaning solutions on the drum surface or on any interior parts of the printer.
- Clear paper jams quickly, especially when they occur in the heat roller unit.
- Do not drop small objects, such as paper clips, into the printer.
- Do not set page margins off the physically printable page area.
- Turn off the printer and disconnect the power cord immediately if an abnormal condition occurs: for instance, if the printer smokes, prints abnormally, becomes wet, or falls. Then consult your dealer.

Contents

Preface	v
Manual and Floppy Disks	v
Operating Environments	vi
Conventions	vi
Control Panel	vii
Chapter 1	
Getting Started	1-1
Getting Acquainted	1-1
Getting Ready	1-4
Picking a Suitable Location	1-4
Unpacking and Checking Your Printer	1-5
Setting Up	1-7
Preparing the Print Unit and Installing the Toner Bottle	1-7
Installing the Cleaner and Cleaner Pad	1-10
Loading Paper and Installing the Paper Tray	1-12
Installing the Multi-function Feeder	1-15
Connecting the Power Cord	1-16
Connecting the Printer to Your Computer	1-17
About Interfacing	1-17
Connecting to the Parallel Port	1-18
Printing a Test Page Offline	1-19
Selecting an Emulation	1-20
Installing the Printer Driver	1-21
Get to Know Your Printer Driver	1-21
Standard Printer Driver for Windows 3.1/3.11	1-22
FPS Printer Driver for Windows 3.1/3.11	1-22
Standard Printer Driver for Windows 95	1-22
Plug and Play Printer Detection	1-23
Set-up from "Printers" Folder	1-23
FPS Printer Driver for Windows 95	1-24
Printing Your First Document	1-26
Adjusting Print Density	1-27
If Something Goes Wrong	1-28
Where To Go From Here	1-29

Chapter 2	Using Printer Software	2-1
	Remote Setup Utility Program, PPMENU	2-1
	Installing PPMENU	2-2
	Factory Defaults	2-4
	Printer Management Utility Program, Lexmark's MarkVision	2-6
	Installing MarkVision	2-6
	Menu Bar Functions	2-7
Chapter 3	Printing and Paper Handling	3-1
	Control Panel Tutorial	3-1
	The Control Panel	3-1
	Indicators	3-2
	Message Display	3-3
	Buttons	3-3
	Control Panel Functions	3-5
	Changing Message Language	3-5
	Printing Data Remaining in the Buffer	3-5
	Clearing an Error Condition to Continue Printing	3-5
	Clearing the Buffer and Reinitializing the Printer	3-6
	Printing a Status Report	3-6
	Printing a Font Report	3-8
	Selecting Paper Tray, MFF, or Manual Paper Feed	3-10
	Setting MFF Paper Size	3-11
	Selecting Menu Option and Resetting Menu	3-12
	Menu Functions	3-12
	Menu Structure and How to Use Control Panel Buttons	3-12
	Submenus, Items, and Options	3-13
	Menu Items	3-16
	Handling Paper	3-20
	Paper Types and Sizes	3-20
	General Tips	3-22
	Preprinted Sheets	3-23
	Transparencies	3-23
	Envelopes	3-24
	Labels	3-25
	Changing the Paper Tray Size	3-25
	Using the Multi-function Feeder	3-27
	Feeding Paper Manually	3-29
	Setting Up the Rear Stacker	3-30
	Printing on Nonstandard Size Paper and on Envelopes	3-31
	Considerations on Paper Size	3-31
	Page Orientation	3-32

Chapter 4	Enhancing and Customizing the Printer	4-1
	Adding RAM	4-1
	Installing an Interface Expansion Board	4-4
	Installing an Interface Board	4-4
	Connecting to the Serial Port	4-5
	Connecting the Serial Interface Cable	4-5
	Selecting the Serial Interface	4-6
	Verifying Serial Parameter Settings	4-6
	Connecting to the LocalTalk Port	4-7
	Connecting the LocalTalk Interface Cable	4-8
	Selecting the LocalTalk Interface	4-8
	LocalTalk Specifications	4-8
	Connecting to the Ethernet Port	4-9
	Connecting the Ethernet Interface Cable	4-9
	Selecting the Ethernet Interface	4-10
	Ethernet Specifications	4-10
	Adding Paper Sources	4-10
	Paper Feeder	4-10
	Changing the Paper Tray Size	4-12
	Different Paper Tray Sizes	4-15
	Adding Duplex Unit	4-15
Chapter 5	Maintenance	5-1
	Preventive Maintenance	5-1
	Periodic Routine Maintenance	5-2
	Replacing the Toner Bottle and Cleaner Pad	5-2
	Replacing the Print Unit and Internal Cleaning	5-7
	Removing the Print Unit	5-8
	Cleaning the Paper Path	5-10
	Cleaning the Corona Wire	5-10
	Cleaning the Paper Guide before the Corona Wire	5-11
	Installing the New Print Unit	5-12
	Resetting the Print Unit Counter	5-15
	Cleaning the Precharger Wire	5-17
	Repacking the Printer	5-18

Chapter 6	Solving Problems	6-1
	Clearing Paper Jams	6-1
	Operational Problems	6-10
	Print Quality Problems	6-11
	Error Indications	6-13
	Action-required Status Indications	6-16
	Printer Status Indications	6-17
	Warning Messages	6-18
Appendix A	Font Samples	A-1
	PCL Mode	A-1
	FPS Mode	A-2
Appendix B	Supplies and Accessories	B-1
	Supplies	B-1
	Accessories	B-1
Appendix C	Specifications	C-1
	Glossary	GL-1
	Index	IN-1
	Fujitsu Offices	Inside back cover

Preface

Thank you for purchasing the Fujitsu PrintPartner 14ADV Page Printer. The PrintPartner 14ADV is a 14-ppm, 600-dpi, laser printer. It is compatible with the HP LaserJet 4 printers or PostScript level 2 printers which are main printers of the industry-standard page printers.

Available options are:

- 1-, 2-, 4-, 8-, 16-, and 32-megabyte memory expansion cards
- Interface expansion boards: serial interface, LocalTalk, and Ethernet C
- Paper trays (trays 1 and 2): A4, A5, letter, legal, and executive sizes
- Paper feeder: Base mechanism plus paper tray (tray 2)
- Duplex unit: Two-sided printing mechanism

Manual and Floppy Disks

The PrintPartner 14ADV has a single user's manual. This user's manual provides a summary of everything for from non-technical users unfamiliar with page printers to highly experienced technical users.

The PrintPartner 14ADV comes with seven floppy disks.

- Windows Printer Drivers (two disks) which provide the computer's operating system with the programs that control this printer.
- MarkVision (three disks), printer management utility program, which allows you to easily understand the printer (status, statistics, or features) and displays the printer control panel on your computer display to remotely operate the printer.
- Network Printer Utility (one disk), which allows you to remotely change or confirm settings of Ethernet C board of the printer or locally check the printer.
- PPMENU (one disk), the printer remote setup utility program, which allows you to easily customize and program your printer to your computer and software environments, using your computer keyboard and display.

Operating Environments

To run the Printer Driver, you need an IBM PC/AT or PS/2 computer or compatible running MS-Windows 3.1/3.11 or MS-Windows 95.

To run MarkVision, you need an IBM PC/AT or PS/2 computer or compatible running MS-Windows 95 (not MS-Windows 3.1/3.11), with at least 5MB of memory available on a hard disk, a 3.5" double-sided high density (2HD) floppy disk drive, and a VGA (640 × 480 dots) or higher resolution display.

To run the Network Printer Utility, you need an IBM PC/AT or PS/2 computer or compatible running MS-Windows 3.1/3.11 (not MS-Windows 95), with at least 5MB of memory available on a hard disk, a 3.5" double-sided high density (2HD) floppy disk drive, and a VGA (640 × 480 dots) or higher resolution display.

To run PPMENU, you need an IBM PC/AT or PS/2 computer or compatible running MS-DOS, with at least 1MB of memory available on a hard disk, a 3.5" double-sided high density (2HD) floppy disk drive, and a VGA (640 × 480 dots) display. You must also be using PC-DOS version 5.02, MS-DOS version 3.3, or higher version.

Conventions

Icons draw your attention to advisory messages, as illustrated below. A line precedes and follows the message to show where the message begins and ends.



Caution:

Ignoring this information could result in personal injury.



Notice:

Ignoring this information could result in loss of data or harm to your equipment.



Important:

These notes contain remarks, tips, and other useful supplementary information.

Control Panel

The printer's control panel incorporates two rows of buttons, with each button having one or two labels (see below). The physical button is beneath the rectangular section of no-labeled space. The top label represents the basic function, which is activated by a touch of the button. The bottom label represents the second function, which is activated when you release the button after holding it down more than five seconds.

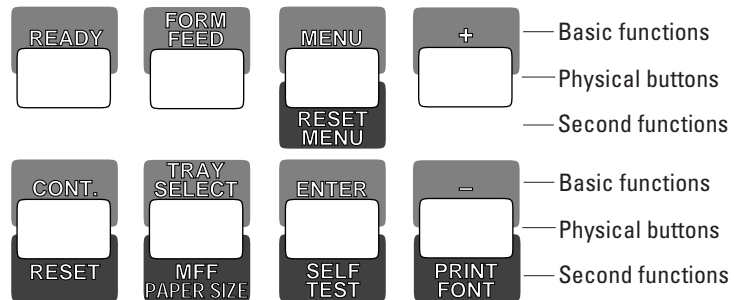

The control panel has a character display of 16 columns \times 2 lines.

In text, the names of the control panel buttons appear as all capital letters inside a box like `READY` and control panel display messages appear in a fixed-spacing font like `READY`. Button names or messages occupying two lines are expressed in a single line shown below.

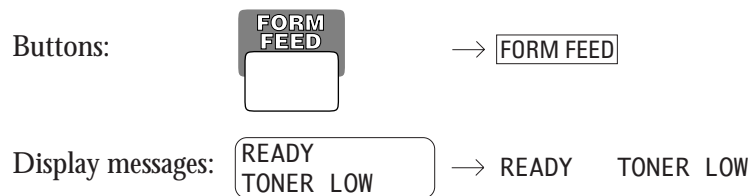

The asterisk in the display column indicates that the displayed option is currently selected in the selected menu.

Changing Message Language (MENU)

You can select a language used for control panel messages. Selectable languages are English, French, German, Italian, Spanish, and Swedish.

To select a language, follow these steps:

- 1. Turning the printer on while pressing MENU.**
The message C . P . LANGUAGE ENGLISH appears after printer initialization.
- 2. Press the + or - button until the desired language appears. Press the ENTER button.**
The asterisk appears after the language, indicating the language is selected.
- 3. Save the selection.**
Pressing the READY button saves the new setting and returns the printer to the ready state. The printer will display the selected language for messages.

Getting Started

This chapter provides complete setup instructions in the following sections:

- *Getting Acquainted.* Learning the printer's main parts and its paper paths.
- *Getting Ready.* Choosing a suitable location and unpacking the printer.
- *Setting Up.* Assembling the printer.
- *Connecting the Printer.* Selecting an interface and connecting to the computer.
- *Installing the Printer Driver.*
- *Printing Your First Document.*
- *Where to Go from Here.*

Getting Acquainted

The illustrations on the following pages identify the main parts of the printer and two routes of paper feeding. These parts are referred to throughout the manual, so take some time to become familiar with them.

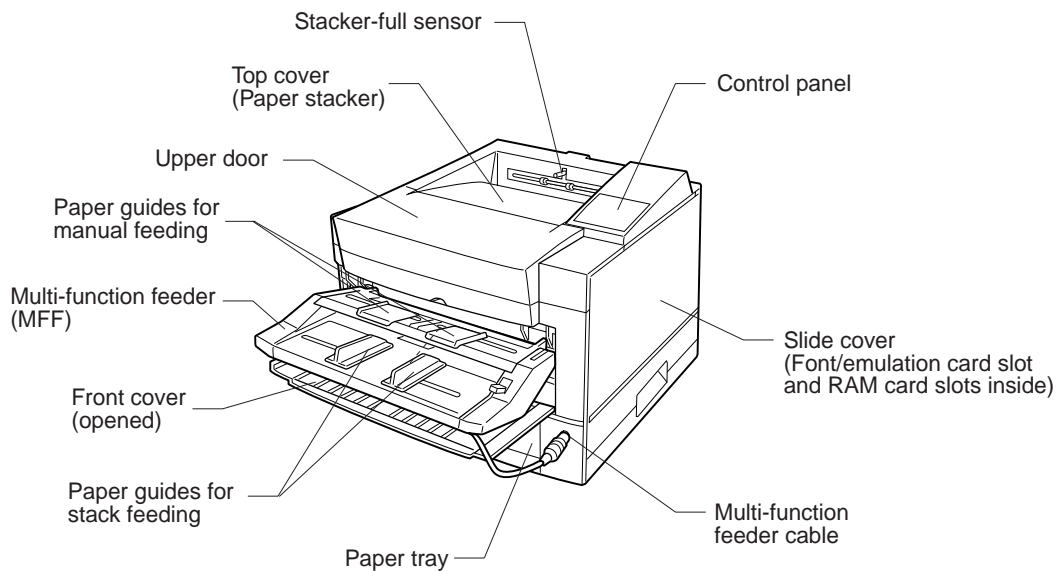

Figure 1-1 Front and right side view

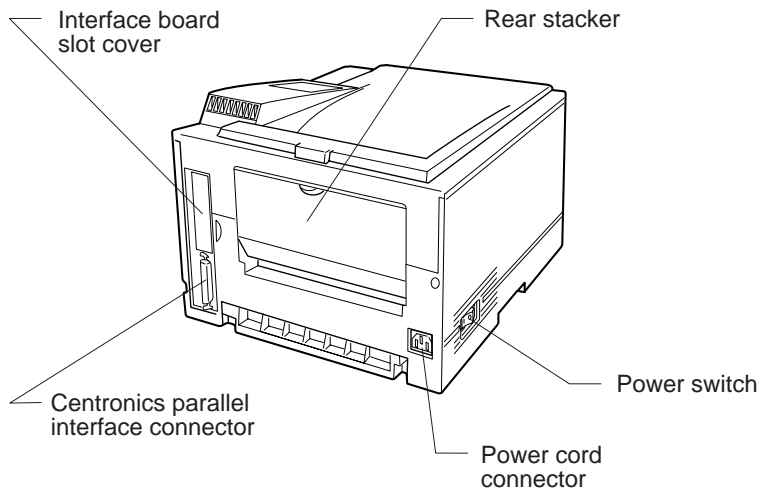

Figure 1-2 Rear and left side view

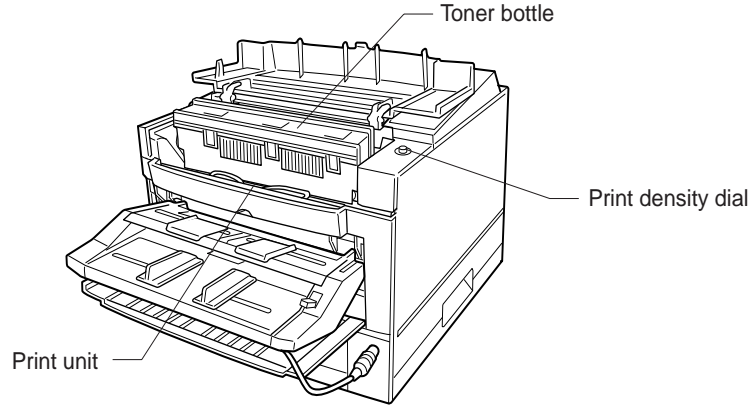

Figure 1-3 Interior view

The path from the paper tray to the top cover is for ordinary paper. The straight path from the manual feed slot or optional multi-function feeder to the rear stacker is for transparencies and envelopes.

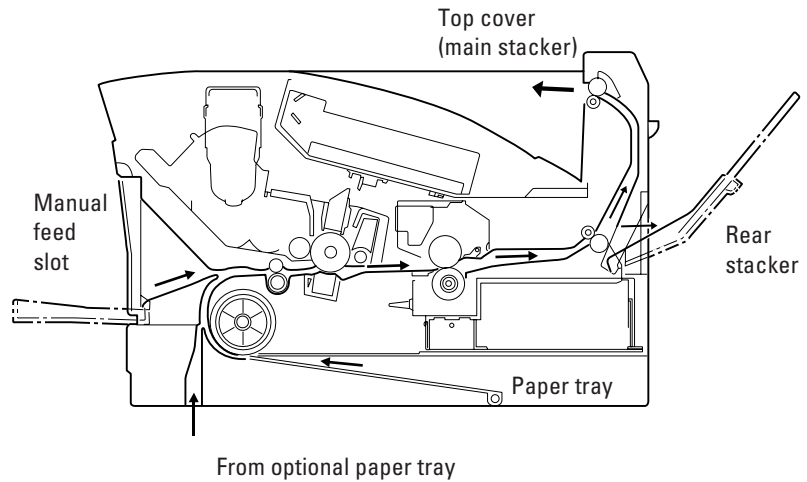

Figure 1-4 Paper paths

Getting Ready

This section will help you:

- Choose a suitable location for the printer
- Inventory the parts of the printer as you unpack it

Picking a Suitable Location

The first step is to pick a suitable location for your printer. For peak performance and usability, follow these guidelines:

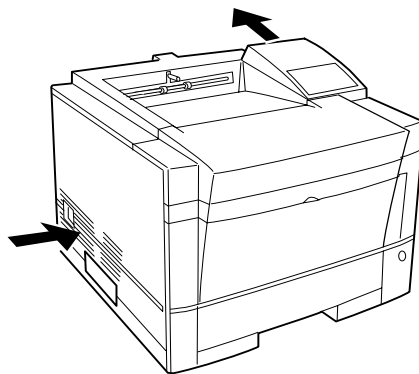

- Place the printer on a sturdy, level surface.
- Choose a room that is well ventilated and free of excessive dust. Leave space on either side of the printer for proper ventilation.

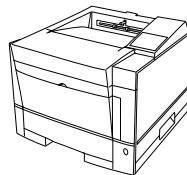

- To avoid exposing the printer to extremes of temperature, do not put the printer in direct sunlight or near a heater. Ideal room temperature is from 10°C to 35°C (50°F to 95°F). Humidity should be between 20% and 80% RH (no condensation).

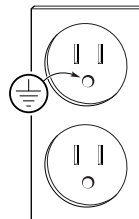

- Use a grounded AC power outlet. Do not use a three-pronged adapter in an ungrounded outlet.

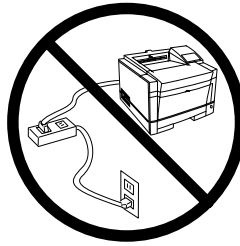

- Use only the power cord furnished with the printer. Do not use an extension cord.

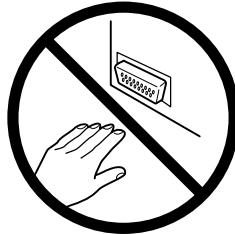

- Do not touch any connector contacts and corona wires to avoid possible electrostatic damage to the printer.



- Do not use a circuit shared with equipment that causes electrical noise, such as motors.
- Do not use a circuit shared with equipment that uses a lot of power, such as a copier or a coffee maker.

Unpacking and Checking Your Printer

As you unpack the printer, check each item carefully for damage. If you find damage, notify your dealer. Check also that you have received all the items shown below.

This printer comes with everything you need except an interface cable. If you do not yet have a cable, you must purchase one before you can connect the printer to your computer.



Important:

Save the original carton and packing materials in case you need to store or transport your printer.

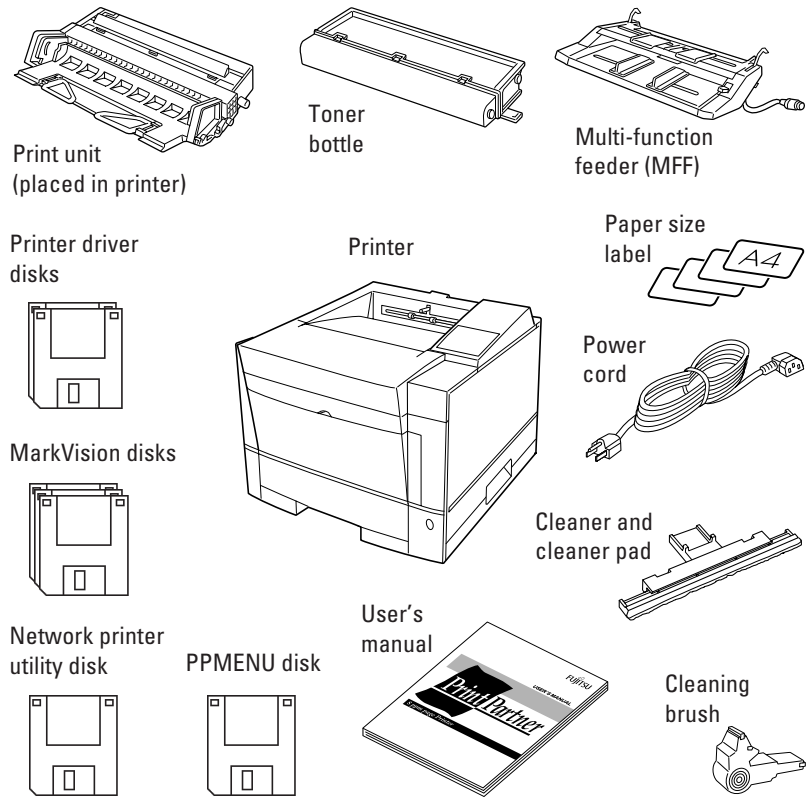

- An interface cable is not a standard accessory. Please purchase an appropriate cable according to the interface you intend to use.
- The power cord may differ slightly from this figure depending on the country where you purchased the printer.
- The multi-function feeder (MFF) is separately packaged.

Figure 1-5 Printer inventory

Setting Up

This section describes how to assemble the printer and connect the power cord after choosing a suitable location for the printer and checking that you received all the parts.

GETTING
STARTED

Preparing the Print Unit and Installing the Toner Bottle

This printer is shipped with the print unit mounted and protective materials attached. Be sure to remove the two protective materials from the print unit. This operation is possible with the print unit mounted. First prepare and install the following two components:

- Print unit (photoconductor drum, developing unit, etc.)
- Toner bottle

The toner bottle first installed after you purchase the printer will last about 2500 printed pages under the condition of 5% coverage on A4 paper. The succeeding toner bottles last about 5000 printed pages each.



Notice:

Do not touch any connector contacts and corona wires to avoid possible electrostatic damage to the printer.

Be careful with the print unit's drum (the green surface). The drum is easily damaged by contamination or by exposure to light for more than three minutes. Follow these guidelines:

- Never touch or scratch the drum surface.
 - When the print unit is not in the printer, store it in a dark place or cover it with a clean sheet of paper.
 - When the print unit is in the printer, keep the printer top cover closed. If you must work inside the printer for more than three minutes, remove the print unit with the toner bottle mounted and store it in a dark place.
-

To prepare the print unit and install the toner bottle, follow these steps:

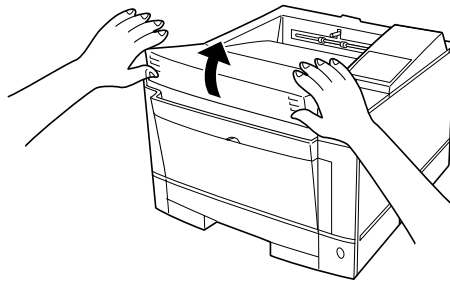

1. **Open the upper door.** Lift the milled portions at the front left and right of the upper door to open it.

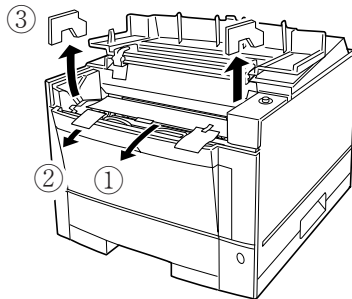

2. **Remove the protective materials from the print unit.** Remove protective sheet ①. Pull clear tape ② until its blue end is visible and remove it. Remove two restraint cushions ③.

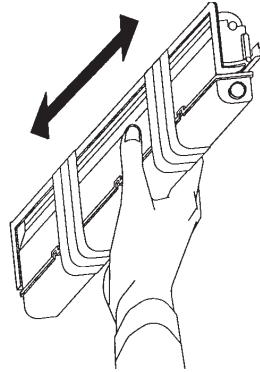

3. **Remove the toner bottle from its bag.**
4. **Shake the toner bottle by moving it back and forth in a horizontal motion several times.**

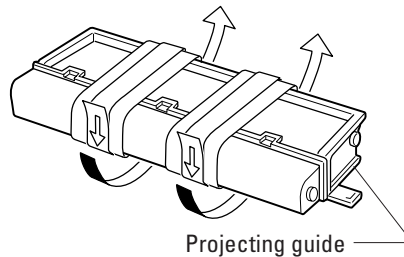

5. **Remove the plastic seal from the toner bottle.** Gently pull off the seal being careful not to spill toner. Handle to seal carefully to avoid staining your hands or clothes.

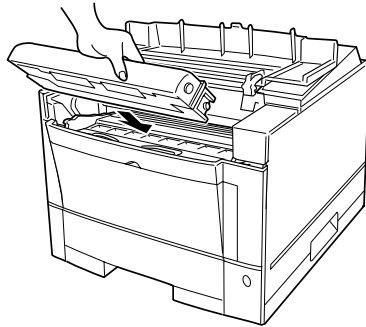

6. **Install toner bottle.** Slide both projecting guides of the toner bottle into the grooves of the print unit.



Notice:

If you have installed the toner bottle, do not remove it from the print unit until it is empty. This could cause toner to spill into the printer.

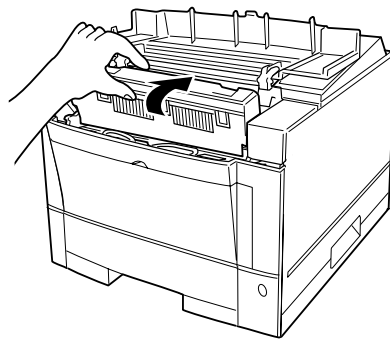

7. **Lock the toner bottle.** Push the toner bottle forward until it clicks into place. (The bottle stands nearly upright when installed correctly.)

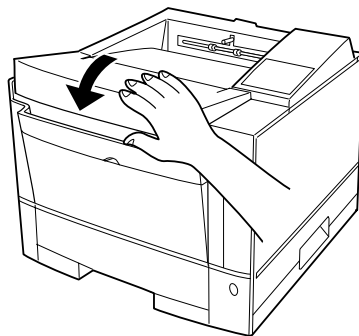

8. **Close the printer's upper door.** Press down firmly on the front portion of the upper door and make sure the upper door is locked completely.

Installing the Cleaner and Cleaner Pad

This printer is shipped without installing the cleaner and cleaner pad which removes dirt from the pressure roller in the fuser unit. Be sure install the cleaner and cleaner pad before printing.

To install the cleaner and cleaner pad, follow these steps:

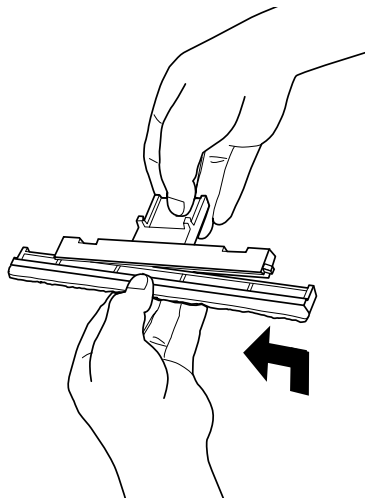

1. **Mount the cleaner pad on the cleaner.** Put the cleaner pad on the cleaner and slide the cleaner pad into the locked position.

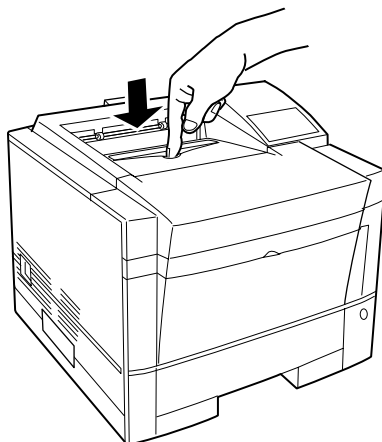

2. **Open the cover.** Push the engraved portion on the stacker to unlock the cover.

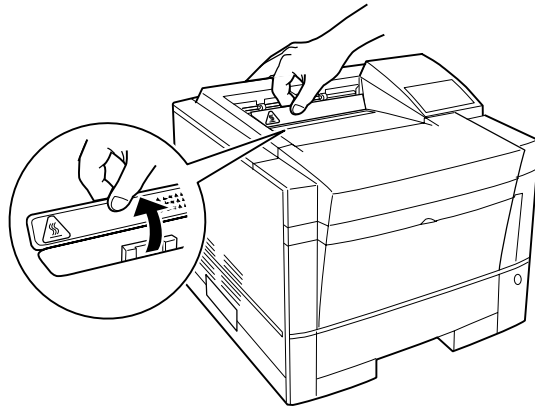

3. **Lift the front of the cover to open the cover.**

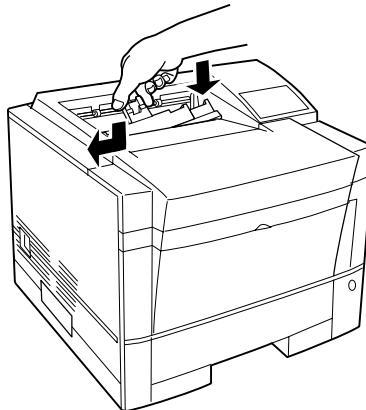

4. **Install the cleaner in the printer.** Grasp the handle of the cleaner and put the left end of the cleaner into the opening, and then the right end.

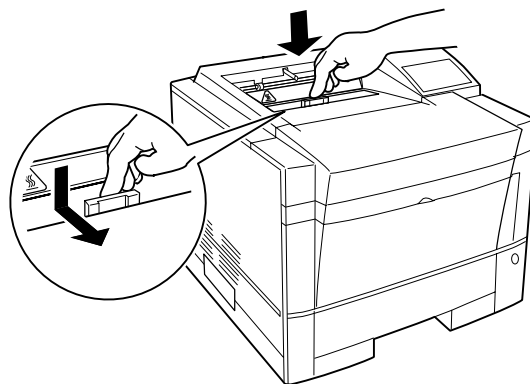

5. **Lock the cleaner.** Push down the top of the handle and pull it towards you to lock the cleaner.

6. **Close the cover.**

Loading Paper and Installing the Paper Tray

This printer has a single paper tray that is preset for letter size (8.5 x 11.0 inches) paper for U.S. customers and to A4 size (210 x 297 mm) paper for European customers. (You can adjust the paper tray to a different size paper. See Chapter 3. You can purchase an optional paper tray. See Chapter 4 and Appendix B.) You should load about 50 sheets of copier paper to test the printer.

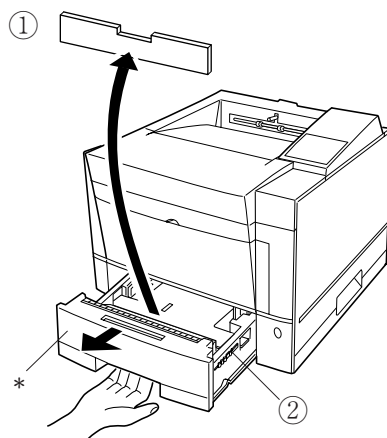

1. **Pull the paper tray out of the printer.**

2. **Prepare the paper tray.** Remove restraint card board ① and tapes securing the rear paper guide. Check green indicator ② is positioned according to the tray size label (*).

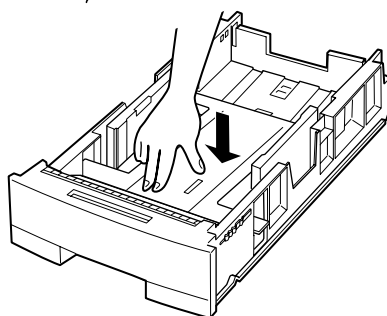

3. **Lock the pressure plate.** If the front of the pressure plate is raised, push it down until the pressure plate clicks into place.

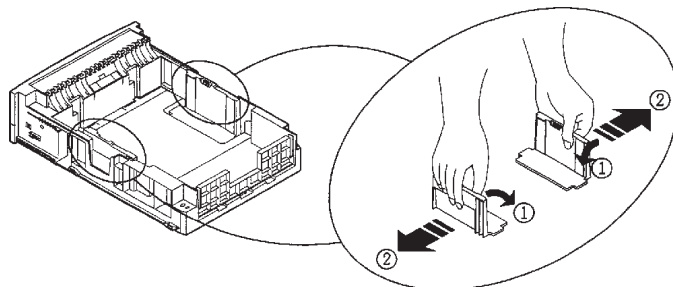

4. **Widen the side guides.** While bending both side guides inward ①, push their inner PUSH marks outward ②.

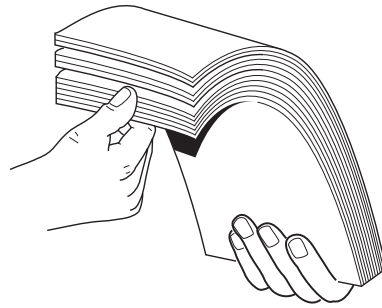

- Prepare a paper stack.**
 Prepare paper of the size indicated by the size label (*). Fan the paper stack both ways to prevent sheets from sticking together.



Notice:

Put the paper stack in the paper tray with the printing side faced down.

If paper is curled, remove the curl.

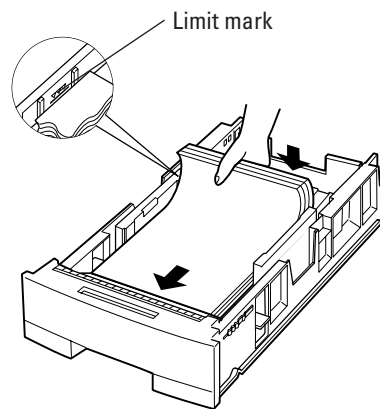

- Load the paper.** Place the front portion of the paper stack on the tray and slide it backwards so that the stack is placed under the two stoppers. Gather the edges of the stack together to ensure correct positioning of paper in the tray.

Make sure the stack does not exceed the limit mark.

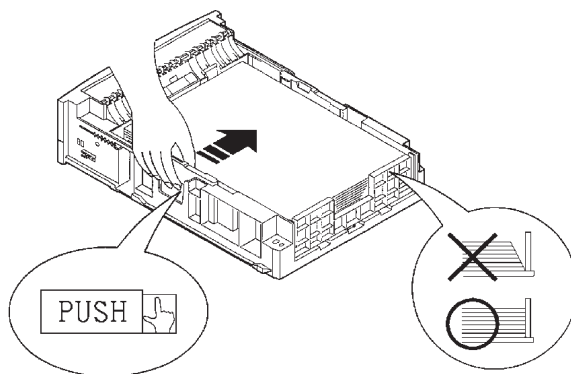

- Adjust the side guides.** Push the outer PUSH mark of either side guide to the width of paper. Align the rear edges of the paper stack.

Bad placement

Good placement

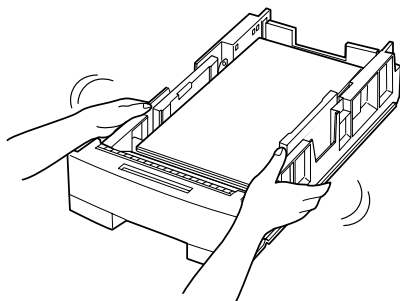

8. **Arrange paper edges.** Rock the paper tray to gather the edges of the stack together to ensure correct positioning of paper in the tray.

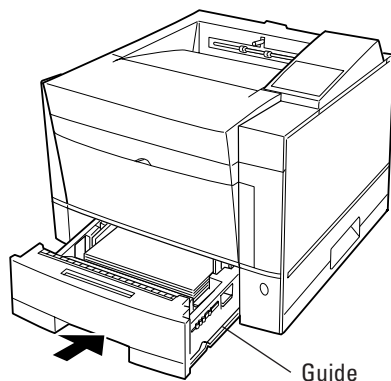

9. **Install the paper tray.** Align the sides of the tray with the guide grooves of the tray slot (the left groove is engraved with an arrow) and firmly slide the tray all the way into the slot.



Notice:
You cannot install the paper tray with the pressure plate raised.

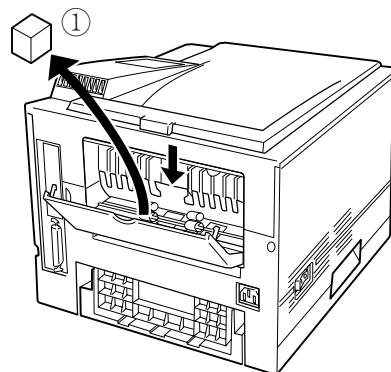

10. **Remove the protective material from the rear stacker.** Open the rear stacker and remove restraint cushion ①. Make sure the paper guide is pushed down in the locked position. Close the rear stacker.



Notice:
If the paper guide is not in the locked position, the printer will not work.

Installing the Multi-function Feeder

The multi-function feeder (MFF) is useful to print a lot of envelopes or transparencies. The MFF can hold and deliver 100 sheets of 0.09 mm thick paper or 30 envelopes. Note that the printer works if the MFF is not installed.

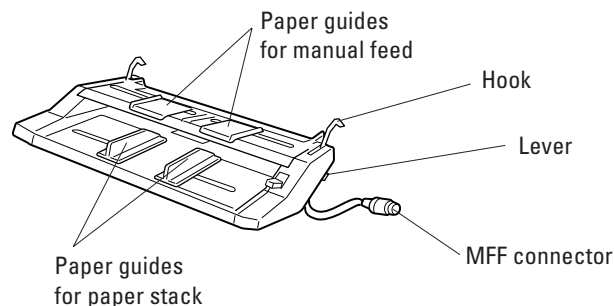

Notice:

When using paper, do not leave the paper in the multi-function feeder for long time. It may cause waving of paper and dropouts in printing.

Because the MFF does not have a mechanism that detects the physical size of paper in use, you must inform the printer of the paper size. Use the MFF paper size menu to select a paper size which equals the size of paper loaded in the MFF.

To install the multi-function feeder, follow these steps:



Notice:

Be sure that the printer is turned off before installing or removing the multi-function feeder.

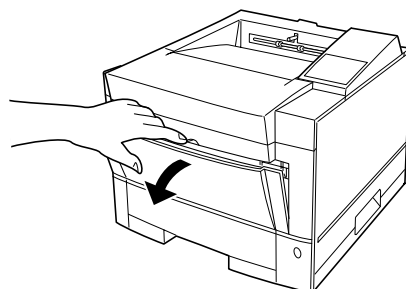

1. Open the front cover.

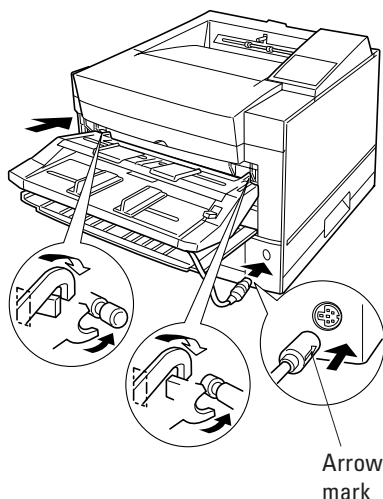

2. **Fasten the feeder to the printer.** Insert the left and right supports and hooks of the multi-function feeder into the corresponding openings at the front of the printer so that the hooks catch the pins firmly.
3. **Connect the feeder cable.** Connect the feeder cable to the connector at the right side of the printer. Orient the arrow mark of the cable's connector right.



Notice:

To avoid paper jams or other feeding errors, make sure that each of the left and right hooks securely hangs on the pin.

Connecting the Power Cord

This printer comes equipped with one of the two voltage ratings:

- 120 VAC (such as for the USA)
- 220 to 240 VAC (such as for Europe)

The manufacturer's nameplate on the back of the printer indicates this rating. Confirm that the rated voltage of your printer matches the voltage of your power outlet.

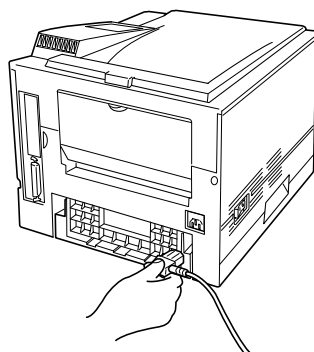

1. Check that the printer is turned off. The "O"-marked side of the switch should be depressed.
2. **Plug the female end of the power cord into the connector on the left back of the printer.**

3. Plug the male end into a wall outlet.

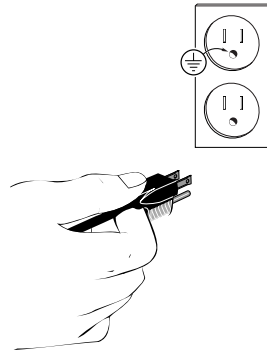

Caution:

For your safety, use only a properly grounded outlet. To avoid possible electromagnetic interference or power supply problems, do not use an extension cord.

Connecting the Printer to Your Computer

This section explains how to connect the printer to your computer via the parallel interface. For information about the serial interface (option), see Chapter 4.



Notice:

The following restrictions apply to interface cables:

- To comply with regulations for radio frequency emissions, use only shielded cable for computer-to-printer communications.
- The length of the parallel interface cable must be 3 meters (10 feet) or less.

About Interfacing

You can connect the printer to your computer using a standard parallel interface. Many computers have a parallel interface port. However, if your computer does not have the parallel interface port, or for printers used in a network, the following optional interfaces are available.

- **Serial (RS-232C/422A)**
Use a serial interface if the printer is not near the computer. Many computers have both parallel and serial interface ports. Serial communication can operate up to 15 meters (50 feet). Parallel communication is normally limited to 3 meters (10 feet).
- **LocalTalk**
Use the LocalTalk interface if the printer is connected to a Macintosh network.
- **Ethernet C**
Use Ethernet C if the printer is used in a NetWare or UNIX environment.

For any of these options refer to Chapter 3.

Connecting to the Parallel Port

This printer does not come with a parallel interface cable. You can use a standard Centronics interface cable (sold separately) for this purpose. Your dealer can advise you on the cable you require.



Notice:

Be sure the printer is turned off before connecting the interface.

Do not touch any connector contacts or corona wires to avoid possible electrostatic damage to the printer.

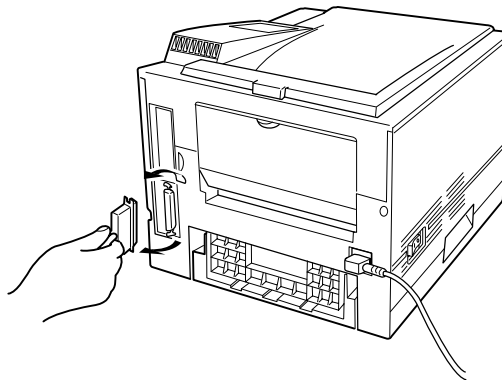

To make the connection, plug the cable connector into the parallel interface port on the back of the printer. Secure the connector with the wire clips. Plug the other connector into your computer's parallel port. Consult your computer documentation if you need help.

Printing a Test Page Offline

The printer has a status report function which prints a page summarizing printer option settings and showing samples of resident fonts. Use this function to check the printer performance offline.

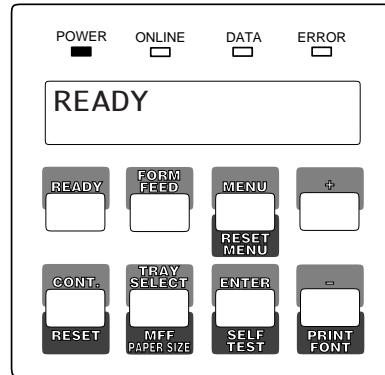

1. **Turn the printer on.** The printer initializes the mechanism and then enters the ready state. The message display indicates <<<INITIALIZE>>>, WARMING UP, then READY.

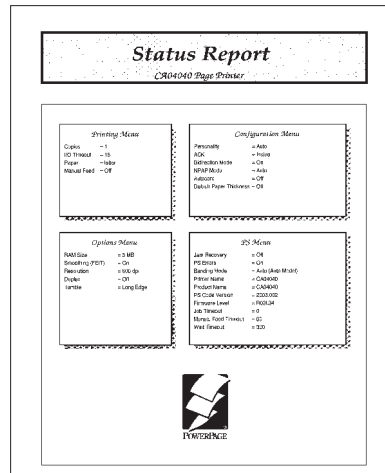

2. **Print a test page offline.** Press the **READY** button to put the printer offline (the ONLINE indicator turns off). Press the **SELF TEST** button for more than five seconds. The message display indicates SELF TEST and the DATA indicator flashes. A status report page is printed. Check that the printing is successful.



Notice:

The status report is for either the PCL emulation or the FPS emulation depending on the emulation you used for printing the last document; however, the status report is for the FPS emulation if it is printed immediately after the printer is turned on. To clearly select the report, use the test menu in setup mode.

Selecting an Emulation

This printer has two emulations (PCL and FPS) as a standard feature. You can use these emulations to connect your printer to different computers. PCL emulates HP LaserJet 4 printers and FPS emulates PostScript Level 2 compatible printers.

With default settings, the printer automatically selects the active emulation. To specify an emulation, select the emulation using the control panel. Use the Personality menu of the Config menu as shown below.

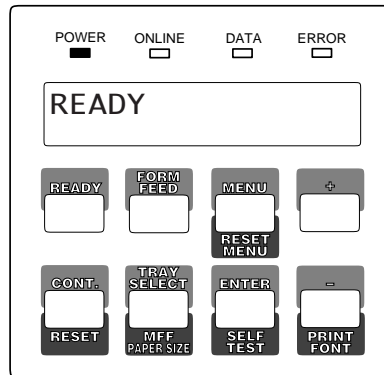

1. **Enter setup mode.** Press the **READY** button to put the printer offline (the ONLINE indicator turns off). Then, press the **MENU** button briefly six times.

The message display indicates SETUP MENU CONFIG MENU.

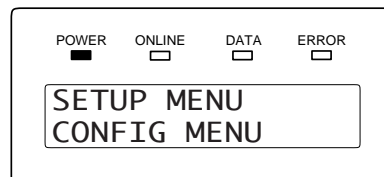

2. **Select the Personality menu.** Press the **ENTER** button briefly. The message display indicates PERSONALITY AUTO*.

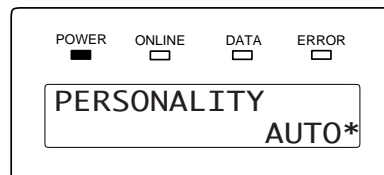

3. **Select emulation.** Press the **ENTER** button briefly. The option AUTO changes to PCL, PS, then back to AUTO. Press the **READY** button when the desired option is displayed.

The selected emulation is selected (an asterisk is followed). Once you change the emulation, the other menus automatically change to reflect the options and functions of the new emulation. For details of the setup menu, see Chapter 3.

Installing the Printer Driver

Now that you connected your printer to the parallel port of the computer, you are ready to install the Windows Printer Driver which controls the printer. There are two printer driver disks which contain Standard Driver for Windows 3.1/3.11, Standard Driver for Windows 95, and FPS Driver for Windows 95. Note that the installation procedure differs.

When you are using Windows 95, it is recommended that you should install the printer driver using MarkVision because the printer driver is reinforced with MarkVision's features such as remotely changing settings of a network printer and checking status of a network printer. For MarkVision, see Chapter 2.

To install a printer driver in Windows 95, note the following:

- When you install the printer driver, the original OS (CD-ROM or floppy disks) is required during installation.
- When MarkVision may be already installed, select a printer name followed by (MV) in the Printers window. When MarkVision is not installed, select a printer name not followed by (MV).

Get to Know Your Printer Driver

The Printer Driver has two functions:

1. it automatically translates formatting choices, such as tab settings or boldface type, into commands the printer understands.
2. it allows you to set up the printer according to your needs (printer settings).

If you encounter problems with this installation, confirm that your configuration corresponds to the minimum requirements listed on page vi at the start of this manual. If the configuration corresponds to these requirements and troubles persist, contact your dealer for assistance.

When running application programs under Windows, you select the printer type in the application program itself before you print a document.

**Notice:**

If you encounter conflicts with other already installed external drivers that use bidirectional communication on the Centronics port or with drivers of other dedicated Windows printers used in parallel with this printer (conflicts like the failure to establish communication between the Printer Driver and the printer), remove these from Windows and reinstall the PrintPartner 14ADV Printer Driver.

Standard Printer Driver for Windows 3.1/3.11

To install the Windows 3.1/3.11 Printer Standard Driver, follow these steps:

1. Start Windows.
2. Insert the PrintPartner 14ADV Printer Driver disk into the 3.5 inch floppy disk drive of your computer.
3. From the Windows Program Manager, select the "File" menu and choose the "Run" command.
4. Type "A:\inst_xxx" or "B:\inst_xxx" and press the "Enter" key.

FPS Printer Driver for Windows 3.1/3.11

This printer driver is not contained in the attached floppy disks. Select a printer driver corresponding to LaserWriter II NTX.

Standard Printer Driver for Windows 95

The Windows printer driver can be installed by either of the following two methods. The first one applies when Windows 95 is started with the printer ready and the second one applies when the printer is on after Windows 95 has been started.

Plug and Play Printer Detection

1. Windows 95 automatically detects the printer at installation time or during the boot process.
2. Plug and Play detection code will prompt the user for the appropriate files, if they are not already resident in the Windows directory, by displaying the “New Hardware Found” dialog box.
3. From the “New Hardware Found” dialog box, select “Driver from disk provided by hardware manufacturer” and click “OK”.
4. The “Install from disk” dialog box will be displayed and you will be prompted to select the drive and directory containing the installation disk.
5. Insert the Printer driver installation disk into the A: or B: drive. Type “A:\” or “B:\” and click “OK”.
6. The “Select Device” dialog box appears displaying the model-name “Fujitsu PrintPartner 14ADV”. Click “OK” to continue.
7. Follow steps 8 to 11.

Set-up from "Printers" Folder

1. Click the "Start" button, point to "Settings", and then click "Printers".
2. Double-click "Add Printer".
3. The "Add Printer Wizard" will appear. Click “Next>”.
4. Click “Have Disk” from the next dialog box. The “Install from disk” dialog box will be displayed and you will be prompted to select the drive and directory containing the installation disk.
5. Insert the Printer driver installation disk into the A: or B: drive. Type “A:\” or “B:\” and click “OK”.
6. A dialog box will display the model-names. Select “Fujitsu PrintPartner 14ADV” and click “Next>” to continue.
7. A list of available Ports appears. Select an appropriate Port and click “Next>”.

8. You will be prompted to type the Printer name. Type an appropriate name or use the one supplied and click “Next>”.
9. The next dialog will prompt you to print a test page. Select “Yes” or “No” and click “Finish”.
10. Driver files should now be automatically copied from the installation disk.
11. When all files have been copied and the driver is installed, a dialog will appear querying the result of test page printout. Depending on whether the test page was printed correctly or not click “Yes” or “No”.

The Fujitsu PrintPartner 14ADV Windows 95 Standard Printer Driver is now installed.

For further details, see the appropriate country version of the driver’s Readme file.

FPS Printer Driver for Windows® 95

1. Start Windows.
2. Click the Start button, point to Settings, and then click Printers. The Printers appears.
3. Double-click Add Printer. The Add Printer Wizard appears. Click “Next>”.
4. Select “Local printer” or “Network printer”.
5. Printer manufacturers and names are listed. Click “Have Disk...”. The “Install from disk” dialog is displayed.
6. Insert the Printer Driver disk into the A: drive and click the “OK”. After the floppy disk files are copied, the dialog box displays the model-name “Fujitsu CA0404x FPS2”.
7. Select “Fujitsu CA0404x FPS2” and click “Next>”. A list of available Ports appears.
8. Select an appropriate Port (usually “LPT1”) and click “Next>”.

9. A dialog appears prompting the user to type the Printer name. Type an appropriate name or use the one supplied and click “Next>”. The next dialog prompts the user to print a test page.
10. Select “Yes” or “No” and click “Finish”. The self test printing should be done to check for correct connection and settings of the printer.
11. When all files have been copied and the driver is installed, the selected printer’s icon is added in the Printers (the screen used in step 1).

The Fujitsu PrintPartner 14ADV Windows 95 FPS Printer Driver is now installed.

For further details, see the appropriate country version of the driver’s Readme file.



Notice:

To avoid possible printer errors, perform the following settings.

- Change the parameter of “Data Compression” in the PostScript tab of the FPS2 driver Properties window to “Medium” to avoid a PS error.
- Change the parameters of “Halftone” in the Graphics tab of the FPS2 driver Properties window to “Use Settings Below”, “80.0” (Frequency), and “45.0” (Angle) to avoid too dark printing or less.

You can also install the driver from MarkVision.

1. Click “Add Printer” of the Printer Installation.
2. Printer manufacturers and names are listed. Click “Have Disk...”. The “Install from disk” dialog is displayed.
3. Follow the procedures from step 6 in the preceding procedures.

Printing Your First Document

Your printer should be set up and connected to your computer. This section explains how to test your installation setup by printing a trial document from an application program under Windows. To test the printer alone, without your computer, you can use the status report printing which does not require the use of a computer. See **Printing a Status Report** in Chapter 3.

Turn on your printer and observe the initialization sequence. If no RAM (extra memory) cards have been installed, the sequence lasts about one minute, during which the following events occur:

- The printer conducts a number of self-checks.
- The main motor rotates to check mechanical functions and clean the drum.
- The message display indicates READY, indicating the printer is ready for printing.

The following procedures show you how to print your trial document.

To print a trial document, follow these steps:

- 1. Start Windows and a Windows application.**
- 2. Open your trial document.**

Select an existing or start a new document. Choose a small document for the first trial.

- 3. Select PP14ADV as the document printer.**

In most programs, you make the selection in a print menu. Consult your program documentation for the exact procedure.

- 4. If desired, change the font(s) in the document to one of the fonts offered by your application.**
- 5. Check the printer.**

Look in the main window of the Print Manager to make sure the printer is activated.

6. Print your document.

Start the program. The default paper size is fixed to A4 (for Europe) or Letter (for the USA). However, you can print a document on a different size of paper using the manual feed slot which you can choose in the Printer Driver's main window.

Adjusting Print Density

If you feel that the printout is too light or too dark, adjust the print density by turning the print density dial. It is located inside the top cover above the control panel. Turning the dial clockwise darkens the print. A counterclockwise adjustment lightens the print. After making the adjustment, close the top cover, print your trial document again, and check the results.

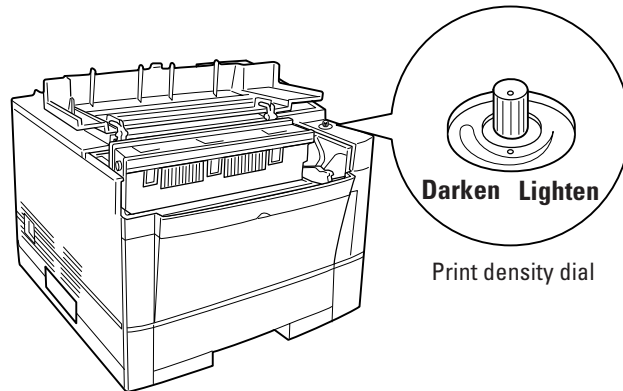

If you see a problem with the printed pages other than print density, see Chapter 6 for possible causes and solutions.

If your document printed successfully, skip the next subsection **If Something Goes Wrong**.

If Something Goes Wrong

This section briefly discusses the most common problems you might encounter. For more complete troubleshooting information, see Chapter 6. Chapter 6 also describes all printer error and status indicators.

Problem	Remedy
No response by printer	Ensure that: <ul style="list-style-type: none">• The printer is turned on and online. The ONLINE indicator should be lit.• The cable from the computer to the printer is properly connected at both ends.• Your software program has sent the print data to the printer. Many programs have a printer control function that shows print
No printout; DATA indicator on	The printer has received data from the computer but has not printed the page. To print the page, put the printer offline by pressing [READY] briefly then press [FORM FEED].
Unreadable printout	Possible causes and solutions are: <ul style="list-style-type: none">• A wrong printer driver is selected. Select the PrintPartner 14ADV printer driver as the document printer.• The document contains unknown printer commands. Remove any setup strings or embedded commands, or print the document with a Text only or ASCII text print option.

Where To Go From Here

To help you enhance or customize the printer, the user's manual contains the following additional information:

- To get information on how to use the control panel and on handling various types of paper, see Chapter 3.
- To customize printer defaults, see Chapter 3.
- To install additional memory, see Chapter 4.
- To load additional fonts, see Chapter 4.
- To install an alternate emulation, see Chapter 4.
- To add an additional paper tray, see Chapter 4.
- To install an additional duplex unit, see Chapter 4.

Using Printer Software

This chapter provides information about the two kinds of printer management software stored in the floppy disks supplied with this printer. The topics are:

- *PPMENU*. Explains PPMENU which enables you to remotely control or configure your printer's features from your computer's screen.
- *MarkVision*. Explains MarkVision which monitors printer status (status is displayed with text and graphics), displays optional printer's features, spools print data, and cooperates with printer drivers. It also describes the printer control panel function by which MarkVision allows you to remotely operate your printer from the printer control panel displayed on your computer's screen.

Note that PPMENU is available in Windows 3.1/3.11 or Windows 95 environments and MarkVision is available in Windows 95 environments.

Remote Setup Utility Program, PPMENU

Generally, the printer driver controls the printer. You can also control the printer using the remote setup utility program called PPMENU, stored in the floppy disk labelled "PPMENU" which is packaged with this manual.

This section focuses on PPMENU, which allows you to easily change your printer's features directly from your computer. You use it to configure your printer to suit the requirements of your computer, software, and documents to be printed.

The parameters you can change using PPMENU affect page layout, font, and printer control. If your software programs have printer drivers, those printer drivers control the parameters for you. Therefore, it may not be necessary to change the settings using PPMENU.

For more details and the latest modifications, refer to the "ReadMe.txt" file in the PPMENU disk.

Installing PPMENU

PPMENU needs to be installed only if you will print from DOS or DOS based applications.

PPMENU first displays the opening screen then the main menu. The main menu offers functions to select print options for your documents. It also offers an operation guide of some keys and a help message line. If the printer is not ready or has an error, a status message is displayed. The top menu bar offers pull-down menus about functions for setup data library, emulation and interface setting, and maintenance. You can select options or perform a function by using the main menu and top menu bar accessed through your mouse or keyboard. One of the six languages (the same one used in your user's manual) is selectable for message display when installing PPMENU.

To use PPMENU, your computer and its operating environments must be as follows:

- IBM PC/AT or compatible or PS/2
- PC DOS 5.02, MS-DOS 3.3, or higher
- VGA (640 x 400) or higher display
- Hard disk drive installed (1 MB essential for PPMENU)
- 3.5-inch double-sided high density (2HD) floppy disk drive (1.44 MB)

PPMENU is supplied with a 3.5 inch double-sided high density (2HD) floppy disk (1.44 MB, 512 bytes/sector). Consult your dealer when your computer does not have the corresponding floppy disk drive.

To install PPMENU files and start PPMENU, follow these steps:

1. Insert the PPMENU disk in the floppy disk drive (suppose A).
2. Type A: then press ENTER.
3. Type \PPMENU2\INSTALL then press ENTER.
4. To run PPMENU, type PPMENU2 then press ENTER.

The following main menu is displayed if the printer has no error after the opening screen is displayed.

Library Special Options		Help	
Page Format Copies 1 == Paper ===== LETTER == Orientation PORTRAIT Formlines 60 Paper Source TRAY 1 Page Protect AUTO Duplex Mode OFF Binding LONG EDGE		(Selectable options window) LETTER * == A4 ===== Executive B5 COM10 DL	
Font Settings		<input type="button" value="SEND"/>	<input type="button" value="EXIT"/>
Print Quality Smoothing (FEIT) ON Resolution 600 Economy Mode OFF Thick Paper OFF		(Operation guide window) ALT+(): Enter: TAB : ESC : Cursor :	
(Help window: describes item indicated by cursor)			

Figure 2-1 PPMENU main menu (concept)

5. You can either use your keyboard or your mouse and left mouse button to perform operations in the main menu. Follow these steps if you will be using a keyboard:
 - Select a pull-down menu: Alt key + L, S, or O key
 - Select (highlight) a feature or option: TAB and cursor keys
 - Confirm or execute: Enter key
 - Cancel: ESC key

To apply new options to the printer, press the Tab key to select the SEND button and press the Enter key. To save the settings, select the "Save current settings" function from the top menu bar.

6. To end PPMENU and exit to DOS or your application, choose the item "Exit" in the "Library" menu or select the EXIT button in the main menu. (PPMENU displays a message asking if the options are to be saved.)

Factory Defaults

PPMENU initially shows the factory defaults of each item in the main menu and the pull-down menus of the top menu bar. Table 2-1 shows the factory defaults and other options. The first three blocks are for the main menu when the PCL emulation is selected as printer personality and the others are for the pull-down menus.

Table 2-1 PPMENU factory defaults when emulation is PCL

Feature	Default	Other options or range
Copies	1	1 to 99 pages
Paper	Letter (*1)	A4, A5, Legal, Executive, etc.
Orientation	Portrait	Landscape
Form lines	60 (*2)	5 to 128 lines
Paper source	Tray 1	Manual feed, Tray 2, MFF, AUTO (Tray 1 not used), AUTO (Tray 2 not used), AUTO (MFF not used), AUTO (All Select) (*3)
Page protect	Auto	On
Duplex mode (*4)	Off	On
Binding (*4)	Long edge	Short edge
Typeface name	Courier	CG Times, Univers, and so on
Font source (*5)	Internal	Soft font, SIMM font
Pitch	10.00	0.44 to 99.99 cpi
Point size	12.00	4.00 to 999.75 point
Symbol set (*6)	Roman8	PC-8, ISO6, ISO11, and so on
Compatible mode	On	Off
Smoothing (FEIT) (*7)	1200 dpi class On	Off (Resolution is 600 dpi) Off (Resolution is 300 dpi)
Resolution	600	300 dpi
Economy mode	Off	On
Thick paper	Off	On

Feature	Default	Other options or range
Personality (*8)	Auto	PCL, PS
Jam recovery (*9) PS error report (*9)	Off Off	On On
Auto continue	Off	On
Acknowledge (*10) I/O timeout (*11)	Inside 15	Outside 15 to 300 seconds
Parallel interface Serial interface	LPT1 COM1	LPT2, LPT3 COM2
Top offset (*12)	0.0	-25.0 to +25.0 mm (0.1 mm steps)
Left offset (*12)	0.0	-25.0 to +25.0 mm (0.1 mm steps)

- *1 Letter for USA and A4 for Europe
- *2 This is for letter and portrait. It automatically changes depending on paper size and page orientation.
- *3 Tray 2 is displayed when the optional paper feeder is installed. MFF is displayed when the optional multi-function feeder (MFF) is installed. AUTO (Tray 1 not used), AUTO (Tray 2 not used), AUTO (MFF not used), and AUTO (All Select) are displayed collectively as AUTO when above options are not installed.
- *4 Duplex mode and binding are valid when the duplex unit is installed.
- *5 Font source is subordinate to the typeface and cannot be selected.
- *6 The screen format changes depending on font information (except for resident fonts) and compatible mode setting.
- *7 FEIT is the acronym for Fujitsu Enhanced Image Technology that makes the contours of objects appear smoother than with this printer's resolution normally possible.
- *8 The screen format changes depending on personality setting.
- *9 Jam recovery and PS error report are valid when the optional FPS card (PostScript level 2 compatible emulation card) is installed.
- *10 This is for the Centronics parallel interface.
- *11 This is essential for sharing the printer among multiple computers.
- *12 Effective when PCL is selected for the personality. These values are used as defaults of top and left offset specifications in PCL mode.

Printer Management Utility Program, Lexmark's MarkVision

MarkVision by Lexmark is an integrated software for managing printers, stored in the floppy disk labelled "MarkVision" which is packaged with this manual. It has the following main functions:

- Monitoring the printer
- Displaying the printer status and features (including options) and statistics
- Providing the printer control panel on the computer's screen (Remote control panel)

These functions are most effective and valuable for remote printers in network environments.

MarkVision is automatically activated when an abnormal condition occurs in the printer. It operates in Windows 95 environments only.

The remote control panel is quite a nice function that enables you to easily and remotely operate the printer even if your printer is set up remotely. MarkVision displays the printer control panel on the computer's screen and gives you the exactly same functions as available with the control panel of the printer. You can perform a function by clicking a button on the computer's screen without pushing a button of the printer's control panel.

Installing MarkVision

To use MarkVision, your computer and its operating environments must be as follows:

- IBM PC/AT or compatible or PS/2
- Microsoft Windows 95 (not Windows 3.1/3.11)
- VGA (640 x 400) or higher display
- Hard disk drive installed (5 MB essential for MarkVision)
- 3.5-inch double-sided high density (2HD) floppy disk drive (1.44 MB)

MarkVision is supplied with three 3.5 inch double-sided high density (2HD) floppy disks (1.44 MB, 512 bytes/sector). Consult your dealer when your computer does not have the corresponding floppy disk drive.

To install MarkVision files and start MarkVision, follow these steps:

1. Insert the Disk 1 of “MarkVision” disk in the floppy disk drive (A or B drive).
2. On the Start menu, click Run.
3. Type A:SETUP, then press ENTER.
4. Follow the instructions on the screen. If you want to install the printer driver, click the Custom box from the Printer Installation dialog.

The following screen is displayed if the printer has no error.

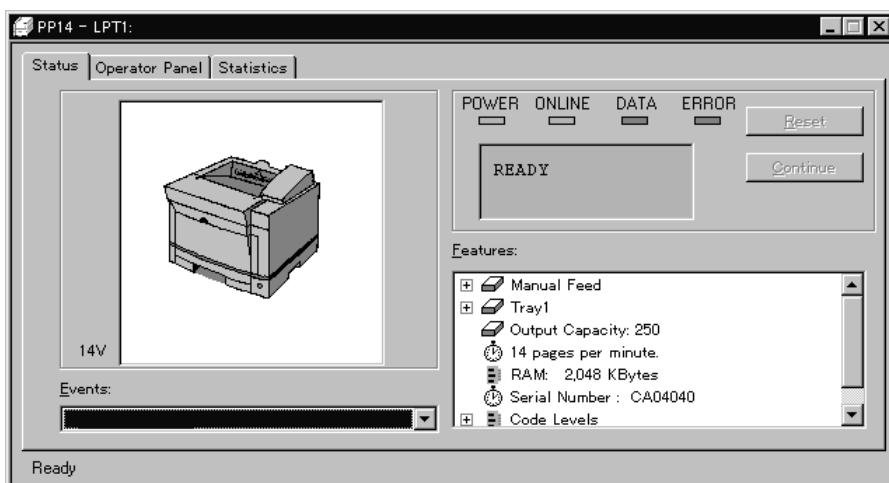

Figure 2-2 MarkVision main screen (status display)

The top menu bar offers three functions. The screen displays information and a graphic of the printer corresponding to the function selected. The bottom line displays printer status.

Help is available from each screen. Highlight the item you want to know more about; then press the F1 key on your computer keyboard. Press the ESC key on your keyboard to exit the online Help.

Menu Bar Functions

The three functions of the top menu bar are as follows:

Status:

Shows a printer status message which is identical to the message appearing on the printer control panel. The status is also indicated graphically. You can determine what the printer is doing and what the printer needs to complete the task. It also includes information about the printer's features including options which are installed on the printer.

With an optional setting, the MarkVision icon flashes to let you know there is a problem with the printer even if the icon is minimized on your monitor.

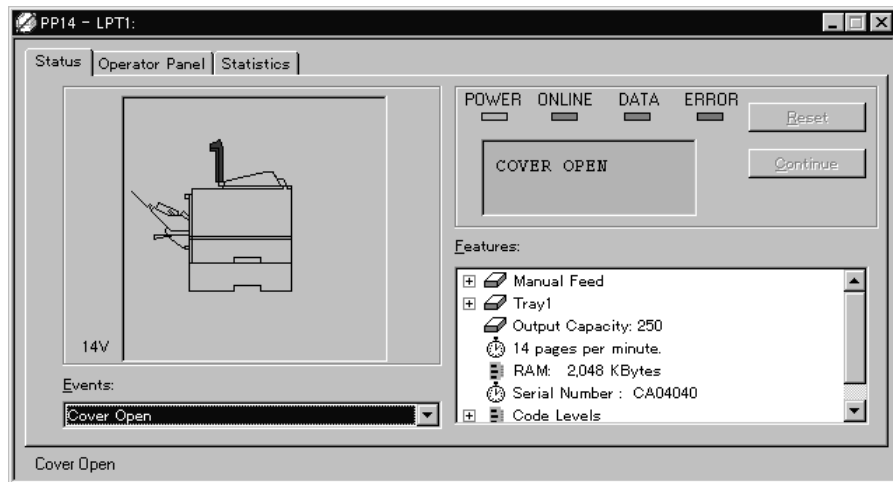

Figure 2-3 MarkVision main screen (cover open status)

Control Panel:

Allows you to remotely operate your printer. It displays an exact replica of the physical control panel on the printer, on your monitor. Click the appropriate button on the screen by the mouse as if you are pressing the real button on the printer control panel by a finger. Both panels have exactly the same functions.

Statistics:

Summarizes details about jobs such as the total number of jobs printed, total pages, and average print time.

Printing and Paper Handling

This chapter provides information you may need for day-to-day printing. The topics are:

- Control panel tutorial

The tutorial describes the indicators, message display, and buttons. It includes an example of how to use the control panel.

- Control panel functions

This section describes the functions by buttons.

- Menu functions

This section describes how to use the control panel for customizing printer defaults.

- Handling paper

This section describes how to print on various types of paper.

Control Panel Tutorial

This section introduces the printer's control panel, beginning with a description of the indicators, message display, and buttons. The tutorial describes the use of the buttons in some detail and follows with an example.

The Control Panel

The control panel consists of four indicators, a message display, and eight buttons. The physical buttons are beneath the LCD display. The top row of labels represents basic functions. The bottom row of labels represents secondary functions. See later in this section for a list of functions.

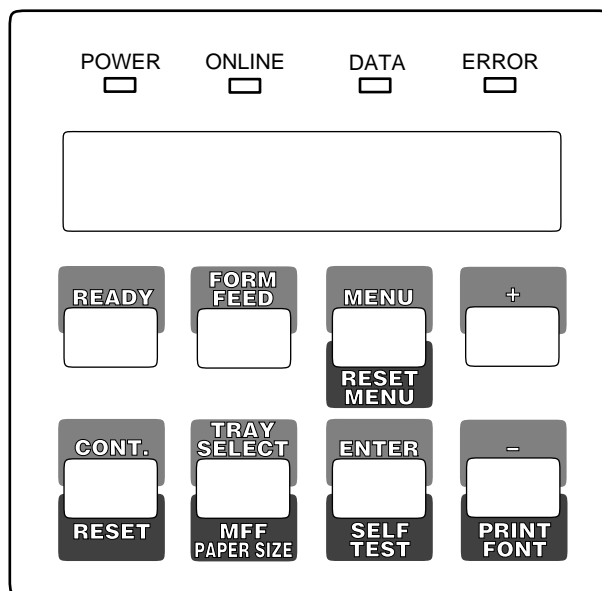

Figure 3-1 Control panel

Indicators

The control panel has four labeled LED indicators across the top.

Indicator	Meaning
POWER	Indicates printer power is on.
ONLINE	Indicates the printer is online and ready to print.
DATA	Flashes when data is being sent from your computer. Lights steadily to indicate the printer's buffer contains unprocessed data.
ERROR	Indicates a printer error has occurred. Details are indicated by the message display.

Message Display (LCD)

The message display uses a liquid-crystal display representing status and errors by two lines of sixteen characters. In operating mode, it may show:

- What the printer is doing
- Whether the printer is ready to print
- When paper should be added
- When paper should be manually inserted
- When the toner bottle needs to be replaced
- When the print unit needs to be replaced
- An error message condition such as paper jam



Important:

A "Ready" message means the printer has no data to print without any errors and the button is not pressed. "Not Ready" means the printer detected an error or the button was pressed in the Ready state.

Error messages inform you of conditions requiring your attention, such as TRAY_n PAPER OUT, COVER OPEN _n, or PAPER JAM_n. They also warn you of hardware problems, such as FUSER FAILURE or BD CYCLE ERROR. The TONER LOW message informs you that the toner bottle needs replacement. See Chapter 6 for a complete list of messages and explanations.

In tray select mode or MFF paper size mode, the message display shows the selected tray or the selected paper size respectively. In menu mode, the message display shows menu items and option selections. These modes are explained later in this chapter.

Buttons

One or two functions are assigned to a button. To use the functions represented by the top labels, simply press the button. To use the functions represented by the bottom labels, press and hold down the button for five or more seconds. The following tables summarizes the functions.

Pressing the button briefly

Except for the **READY** button, the following buttons are also valid when the printer is offline.

Button	Function
READY	Switches the printer between online and offline.
FORM FEED	Performs a form feed to print the remaining data.
CONT.	Clears a recoverable error and continues printing.
TRAY SELECT	Puts the printer in tray select mode which allows you to select the paper tray to be used.
MENU	Puts the printer in setup mode.
ENTER	Selects the displayed option as the printer default. This button and the two buttons below are valid in setup, tray select, or MFF paper size mode.
+	Displays the next option.
-	Displays the previous option.

Pressing and holding down the button for five or more seconds

The following buttons are also valid when the printer is offline.

Button	Function
RESET	Clears the buffer of any print data and puts the printer through its initialization sequence.
RESET MENU	Besides the above reset function, resets all printer operation options to their factory default values except interface settings (parallel menu, serial menu, and network menu).
MFF PAPER SIZE	Puts the printer in MFF paper size mode, which allows you to select the paper size to be used.
SELF TEST	Prints a status report, which lists printer operation options currently selected.
PRINT FONT	Prints a font report, which lists the fonts currently available.

Control Panel Functions

Changing Message Language ([MENU])

You can select a language used for control panel messages. Selectable languages are English, French, German, Italian, Spanish, and Swedish.

To select a language, follow these steps:

1. **Turning the printer on while pressing [MENU].**

The message C . P . LANGUAGE ENGLISH appears after printer initialization.

2. **Press the [+] or [-] button until the desired language appears. Press the [ENTER] button**

The asterisk appears after the language, indicating the language is selected.

3. **Save the selection.**

Pressing the [READY] button saves the new setting and returns the printer to the ready state. The printer will display the selected language for messages.

Printing Data Remaining in the Buffer ([FORM FEED])

Pressing [FORM FEED] tells the printer to advance to the next page. The practical effect is to print any data remaining in the buffer. For example, the buffer might contain data from an interrupted print job. When the buffer contains residual data, the control panel DATA indicator is steadily lit.

Clearing an Error Condition to Continue Printing ([CONT.])

When a recoverable error occurred, pressing [CONT.] clears the error condition and continues printing. For example, you can resume printing after adding paper in response to a TRAY1 PAPER OUT message. You can use [CONT.] to ignore a message such as Load TRAY1 A4. For example, you might want to print a page with A4-size format on a letter-size sheet. [CONT.] also allows you to override the INSERT A4 prompt when feeding paper manually. By pressing [CONT.], the printer prints from tray1 (MFF) instead.

Clearing the Buffer and Reinitializing the Printer ()

Pressing and holding down  for five or more seconds clears the print buffer and tells the printer to initialize itself. You might use this function if you cancel a print job in the middle and want to clear the printer and start over. In this case, permanently downloaded fonts are removed by the initialization process. You must download the fonts again.

Printing a Status Report ()

The status report function prints a page that summarizes printer option settings and shows samples of resident fonts.

To print a status report, follow these steps:

1. **Make sure that the message display indicates **READY** with the **ONLINE** and **DATA** indicators off.**
2. **Press the  button for five or more seconds.**
The message changes to SELF TEST with the DATA indicator flashing and the status report begins printing. After printing, the printer returns to the original state. See Figure 3-2.



Notice:

The status report is for either the PCL emulation or the FPS emulation depending on the emulation you used for printing the last document; however, the status report is for the FPS emulation if it is printed immediately after the printer is turned on. To clearly select the report, use the test menu in setup mode. See Chapter 3.

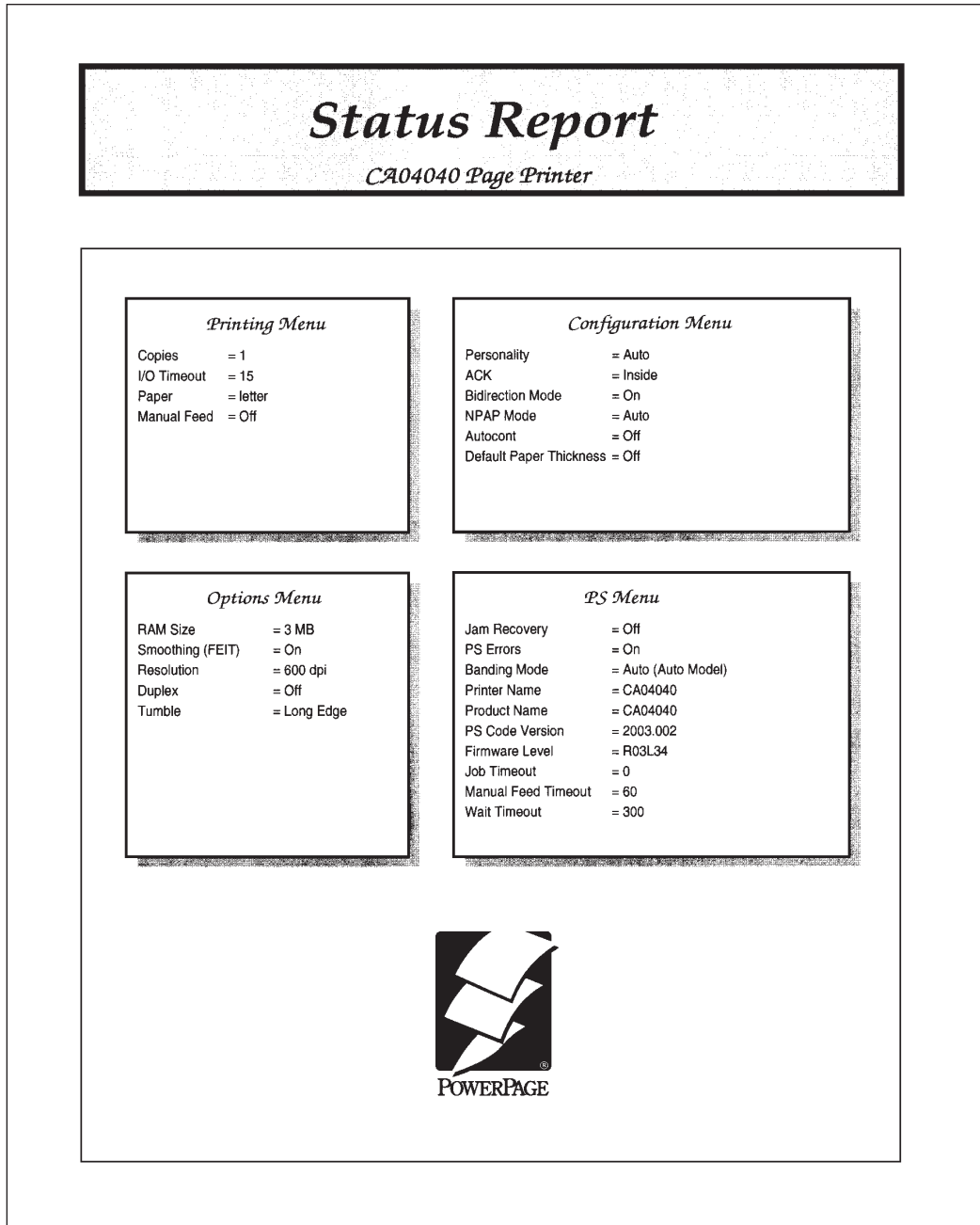



Figure 3-2 Status report (FPS emulation)

Printing a Font Report ()

The font report summarizes attribute information on resident and optional fonts currently available and shows samples of these fonts.

To print a font report, follow these steps:

1. **Make sure that the message display indicates **READY** with the **ONLINE** and **DATA** indicators off.**
2. **Press the  button for five or more seconds.**

The message changes to **PRINT FONT** with the **DATA** indicator flashing, and the status report begins printing. After printing, the printer returns to the original state. See Figure 3-3.



Notice:

The font report is for either the PCL emulation or the FPS emulation depending on the emulation you used for printing the last document; however, the font report is for the FPS emulation if it is printed immediately after the printer is turned on. To clearly select the report, use the test menu in setup mode. See Chapter 3.

35 PostScript Compatible Fonts

CA04040 Page Printer

PRINTING AND
PAPER HANDLING

Courier	ABCDabcd1234!@#\$\$
Courier-Bold	ABCDabcd1234!@#\$\$
<i>Courier-BoldOblique</i>	<i>ABCDabcd1234!@#\$\$</i>
<i>Courier-Oblique</i>	<i>ABCDabcd1234!@#\$\$</i>
Helvetica	ABCDabcd1234!@#\$\$
Helvetica-Bold	ABCDabcd1234!@#\$\$
<i>Helvetica-BoldOblique</i>	<i>ABCDabcd1234!@#\$\$</i>
<i>Helvetica-Oblique</i>	<i>ABCDabcd1234!@#\$\$</i>
Helvetica-Narrow	ABCDabcd1234!@#\$\$
Helvetica-Narrow-Bold	ABCDabcd1234!@#\$\$
<i>Helvetica-Narrow-BoldOblique</i>	<i>ABCDabcd1234!@#\$\$</i>
<i>Helvetica-Narrow-Oblique</i>	<i>ABCDabcd1234!@#\$\$</i>
Times-Roman	ABCDabcd1234!@#\$\$
Times-Bold	ABCDabcd1234!@#\$\$
<i>Times-BoldItalic</i>	<i>ABCDabcd1234!@#\$\$</i>
<i>Times-Italic</i>	<i>ABCDabcd1234!@#\$\$</i>
Symbol	ABXΔαβχδ1234!≡≡
Palatino-Roman	ABCDabcd1234!@#\$\$
Palatino-Bold	ABCDabcd1234!@#\$\$
<i>Palatino-BoldItalic</i>	<i>ABCDabcd1234!@#\$\$</i>
<i>Palatino-Italic</i>	<i>ABCDabcd1234!@#\$\$</i>
NewCenturySchlbk-Roman	ABCDabcd1234!@#\$\$
NewCenturySchlbk-Bold	ABCDabcd1234!@#\$\$
<i>NewCenturySchlbk-BoldItalic</i>	<i>ABCDabcd1234!@#\$\$</i>
<i>NewCenturySchlbk-Italic</i>	<i>ABCDabcd1234!@#\$\$</i>
AvantGarde-Book	ABCDabcd1234!@#\$\$
AvantGarde-Demi	ABCDabcd1234!@#\$\$
<i>AvantGarde-DemiOblique</i>	<i>ABCDabcd1234!@#\$\$</i>
<i>AvantGarde-BookOblique</i>	<i>ABCDabcd1234!@#\$\$</i>
Bookman-Light	ABCDabcd1234!@#\$\$
Bookman-Demi	ABCDabcd1234!@#\$\$
<i>Bookman-DemiItalic</i>	<i>ABCDabcd1234!@#\$\$</i>
<i>Bookman-LightItalic</i>	<i>ABCDabcd1234!@#\$\$</i>
<i>ZapfChancery-MediumItalic</i>	<i>ABCDabcd1234!@#\$\$</i>
ZapfDingbats	☆+·:•+•••*••••••••••••••••••••••••

Figure 3-3 Font report (FPS emulation)

Selecting Paper Tray, MFF, or Manual Paper Feed ()

Pressing puts the printer in tray select mode which allows you to select paper sources to be used. The paper sources are tray 1, tray 2 (if installed), MFF (if installed), and manual feed slot. When a paper source runs out of paper, the printer switches it for another one. When the manual feed slot is selected, other paper sources are made invalid.

To select a paper source, follow these steps:

1. **Make sure that the message display indicates READY with the ONLINE and DATA indicators off.**

2. **Press the button briefly.**

The message changes to TRAY . The asterisk means that tray 1 is selected.

3. **Select or deselect a paper source.**

This step is valid when tray 2 (option) or MFF (standard) is installed. Pressing the button in this condition makes the asterisk disappear. Tray 1 is deselected. Pressing the button again makes the asterisk reappear. Tray 1 is selected.

4. **Select or deselect other paper sources.**

Press the or buttons briefly to display another paper source. Use the button in the same way as described above.

5. **Save the selections.**

Press button to save the new settings and return to the ready state.

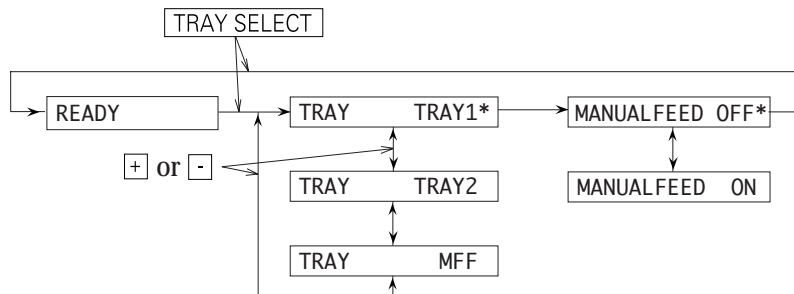

Setting MFF Paper Size (MFF PAPER SIZE)

Pressing **MFF PAPER SIZE** puts the printer in MFF paper size mode which allows you to inform the controller of the physical paper size used in the MFF. You must select the size of paper currently loaded in the MFF. This menu is available when the MFF is installed.

To select a paper size, follow these steps:

1. **Make sure that the message display indicates READY with the ONLINE and DATA indicators off.**
2. **Press the **MFF PAPER SIZE** button for five or more seconds.**
The message changes to MFF PAPER A4*. The asterisk means that A4 size is selected for the MFF.
3. **Select a desired paper size.**

Press the **+** or **-** buttons until the desired paper size appears.

Press the **READY** button. The asterisk appears and the paper size is selected.

4. **Save the selection.**

Press the **READY** button to save the new setting and return to the ready state.

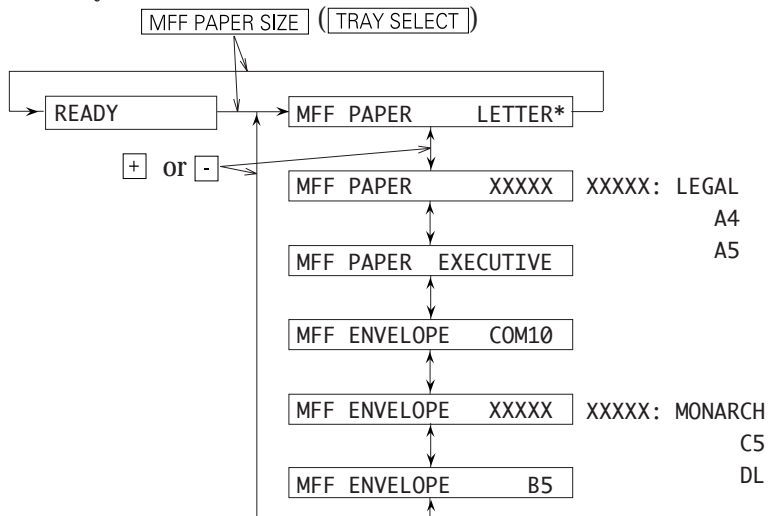

Selecting Menu Option (**MENU**) and Resetting Menu (**RESET MENU**)

Pressing **MENU** briefly puts the printer in menu mode which allows you to set up the printer, for example, selecting a paper size, changing a font, and adjusting serial interface parameters. You can select options from the menu by using the four buttons, **MENU**, **+**, **-**, and **ENTER**.

Pressing **RESET MENU** for five or more seconds in menu mode resets all parameters to the factory default values except interface settings (parallel menu, serial menu, and network menu).

The following section briefly explains the menu mode and its operation.

Menu Functions

The menu mode allows you to change your printer's defaults using the four buttons on the control panel. You can use the control panel's menu mode to configure your printer to suit the requirements of your computer, software, and documents.

Menu Structure and How to Use Control Panel Buttons

The menu mode is structured as a tree consisting of submenus, items, and options. The following example shows a small portion of the tree and illustrates how the four buttons work. (Fig. 2-6)

In the example:

Submenus are PAGE FORMAT MENU and QUALITY MENU. Items are COPIES, PAPER, and SMOOTHING. Options are 001, 002, LETTER, LEGAL, ON, and OFF.

MENU selects menu mode when the printer is ready and offline. Once the printer is in menu mode, **MENU** selects the first submenu and moves you right to the next submenu. If you are on the last submenu, pressing **MENU** returns you to the first submenu.

When a submenu is selected, **ENTER** selects the first item of the submenu. Once the first item is selected, **MENU** moves you right to the next item, regardless of an option selected. If you are on the last item, pressing **MENU** returns you to the first item.

Use **[+]** and **[-]** to move up and down the options list.

When an item is displayed, **[ENTER]** selects that option (adds an asterisk after the option indicating that the option is stored in RAM).

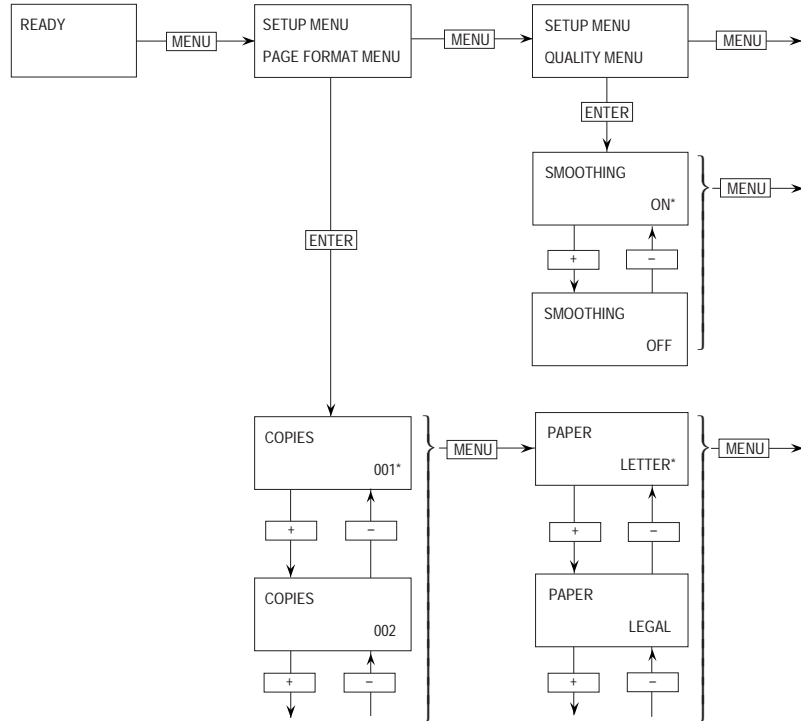

PRINTING AND PAPER HANDLING

Submenus, Items, and Options

The following table shows all of submenus and items and summary of options displayed on the message display in menu mode. The display initially shows the factory default option followed by an asterisk (underlined in the table).

Submenu (bold)/Item	Options
Page format menu	
Copies	<u>001</u> , 002, 003, ..., 999 (pages)
Paper/Envelope	A4, A5, <u>Letter</u> , Legal, Executive (*1) COM10, Monarch, C5, DL, B5
Orientation	<u>Portrait</u> , Landscape
Form lines	005, 006, 007, ..., <u>060</u> , ..., 128 (lines/page) (*2)
Page protect	<u>Auto</u> , On
Duplex mode	<u>Off</u> , On (*3)
Bind	<u>Long edge</u> , Short edge (*3)
Quality menu	
Smoothing (*4)	<u>On</u> , Off
Resolution	<u>600</u> , 300 (dpi)
Economy mode	<u>Off</u> , On
Thick paper	<u>Off</u> , On
PCL font menu	
Font source	<u>Internal</u> , <i>Soft</i> , <i>SIMM</i> (*5)
Font number	<u>000</u> , 001, 002, 003, ..., N (depending on the font source, max. 999)
Pitch size (*6)	<u>0.44</u> , 0.45, 0.46, ..., 99.99 (characters/inch)
Point size (*7)	<u>4.00</u> , 4.25, 4.50, 4.75, 5.00, ..., 999.75 (point)
Symbol set	<u>Roman8</u> , ISOL1, ISOL2, ISOL3, PC8, PC8-DN, PC850, PC852, PC8TK, ..., WingDings
Compatible mode	<u>On</u> , Off
PCL menu (*8)	
Top offset	-25.0, -24.9, -24.8, ..., <u>00.0</u> , ..., +24.9, +25.0 (mm)
Left offset	-25.0, -24.9, -24.8, ..., <u>00.0</u> , ..., +24.9, +25.0 (mm)
A4 print width	<u>Normal</u> , 80 columns/line
FPS menu (*9)	
Jam recovery	<u>Off</u> , On
Print FPS errors	<u>On</u> , Off
Job timeout	<u>0</u> , 10, 11, 12, ..., 298, 299, 300 (0: no check)
Wait timeout	0, 10, 11, 12, ..., 298, 299, <u>300</u> (0: no check)
Manual timeout	0, 10, 11, 12, ..., <u>40</u> , ..., 298, 299, 300 (0: no check)
Banding mode	<u>Auto</u> , Off, On (*10)

Submenu (bold)/Item	Options
Config menu	
Personality	<u>Auto</u> , PCL, PS
Auto continue	<u>Off</u> , On
I/O timeout (*11)	5, 6, 7, ..., <u>15</u> , ..., 298, 299, 300 (seconds)
I/O buffers	<u>Auto</u> , 4K, 16K, 32K, 64K (bytes)
NPAP area size	<u>Auto</u> , Large, Medium., Small
Power save	<u>Off</u> , On after 15 min, On after 30 min, On after 60 min, On after 120 min
Parallel menu	
Acknowledge (*12)	<u>Inside</u> , Outside
Bi-direction	<u>On</u> , Off
NPAP mode	<u>Auto</u> , On, Off
Serial menu (*13)	
Baud rate	1200, 2400, 4800, <u>9600</u> , 19200, 38400, 57600
Format	<u>8Non1</u> , 7Even1, 7Odd1, 8Even1, 8Odd1
Flow control	<u>DTR Hi</u> , DTR Low, XOn/Off, ROBUST XOn/Off
Network menu (*14)	
NPAP mode	<u>Auto</u> , On
Bootp	<u>No</u> , Yes
IP address	###. ###. ###. ### (### = 0, 1, 2, ..., 255) (*15)
IP netmask	###. ###. ###. ### (### = 0, 1, 2, ..., 255) (*15)
IP gateway	###. ###. ###. ### (### = 0, 1, 2, ..., 255) (*15)
Test menu	No option. Pages are printed when an item is selected.
PCL config page	Start
PCL font list	Start
FPS config page	Start
FPS font list	Start
Clear warning	Shows the printing component to be replaced.
<Clear warning>	Print unit

*1 Letter for U.S. customers and A4 for European customers

*2 This is for Letter and portrait. It automatically changes depending on paper size and page orientation.

*3 Valid when a duplex unit is installed

*4 Also called FEIT (Fujitsu Enhanced Image Technology) which makes the contours of objects appear smoother than normally possible with the printers standard resolution.

- *5 Displayed when soft fonts are downloaded or a font SIMM card is installed
- *6 Displayed when the selected font is a scalable and fixed-spacing one
- *7 Displayed when the selected font is a scalable and proportional-spacing one
- *8 Effective when PCL jobs are being executed. These values are used as defaults of top and left offset specifications in PCL mode.
- *9 Displayed when the FPS is selected for personality
- *10 If the total capacity of memory is 3M to 9M bytes with banding mode off, the resolution is automatically set to 300 dpi. When intending to print at 600 dpi, select "banding mode on" or install additional memory cards of 6M bytes or more.
- *11 This is essential for sharing the printer among multiple computers.
- *12 This is for the parallel interface.
- *13 Displayed when a serial interface board is installed
- *14 Displayed when a network interface board is installed
- *15 Consists of four parameters. The one followed by < can be changed.

The following briefly explains each item of the menu mode.

Menu Items

Page format menu

Copies	The number of copies the printer prints from each page
Paper/Envelope	A paper size or envelope size to be used by the printer
Orientation	A printing direction
Form lines	The number of lines printed per page
Page protect	Whether a block of printer memory is reserved exclusively for text and graphics data, especially for printing dense text or complex graphics, to prevent memory overflow errors. However, it reduces the amount of printer memory available for downloadable fonts.
Duplex mode	Two-sided printing mode
Binding	Where an extra area for fastening pages is located, short or long edge of a page

Quality menu

Smoothing	Whether the edge smoothness technology is applied (improves resolution to 1200 dpi class)
Resolution	The number of dots printed per inch
Economy mode	Toner saving mode
Thick paper	Mode for printing thick paper. Be sure to turn this off whenever you are using paper of ordinary thickness.

PCL font menu

Font source	Where the printer finds the font
Font number	The internal number of a font to be selected
Pitch size	Character width (characters per inch)
Point size	Character height (multiple of 1/72 inch)
Symbol set	A set of characters used in a font, consisting of the standard letters, numbers, and punctuation. It differs in the accented characters, line drawing characters, and special symbols by languages.
Compatible mode	PCL5e compatible font mode

PCL menu

Top offset	Distance by which the page is virtually shifted from the top edge of physical paper in PCL emulation
Left offset	Distance by which the page is virtually shifted from the left edge of physical paper in PCL emulation
A4 print width	Setting the width of the printable area for A4 paper size
Normal	PCL5e compatible
80 columns/line	Expands the width of the printable area so that 80 characters of a 10-pitch font can be printed within a line. This setting is available only for A4 paper size in portrait orientation.

FPS menu

Jam recovery	Whether the jammed page is reprinted
Print FPS errors	Whether an error report is printed out
Job timeout	Time interval to be allotted between jobs
Wait timeout	Time interval to be allotted for waiting a job end

Manual timeout	Time interval to be allotted for manual insertion
Banding mode	Switching printing control (band/full page)
Auto	Auto mode (standard setting). Switches the following two modes depending on the total RAM capacity: virtual memory mode for 10MB or less (equivalent to banding mode on) and speed mode for more than 10MB (equivalent to banding mode off)
Off	Speed mode. Attaches importance to speedup of printing control, thus processing all pages per job. Print density is set to 300 dpi when total RAM capacity is 3M to 9M bytes. To print on legal-size paper, set banding mode on, or the total RAM capacity must be 10M bytes or more.
On	(Virtual) memory mode. Attaches importance to reliable printing rather than speedup, thus processing data per page.
Config menu	
Personality	Selecting an emulation (personality) without a PJI command which clearly specifies the emulation
Auto continue	Automatic control of continuing recoverable errors
I/O timeout	Time interval allowed for switching the interface
I/O buffers	Size of interface buffer
NPAP area size	Size of work area for NPAP (network printer alliance protocol)
Power save	Setting the time interval during which the printer remains idle state before sleep mode after printing last
On after 15 min	Power save mode on. The printer enters sleep mode after remaining idle state for ## minutes after printing last.
On after 30 min	
On after 60 min	
On after 120 min	
Off	Power save mode off. (Even in this mode, the printer enters sleep mode after remaining idle state for 180 minutes.)

Parallel menu

- Acknowledge The timing of the ACK signal against the BUSY signal
- Bi-direction Bi-directional Centronics interface mode
- NPAP mode Whether the NPAP commands are used. When using MarkVision, the NPAP mode must be Auto or On.

Serial menu

- Baud rate Data transfer speed on the serial interface
- Format Data format for the serial interface. The first digit indicates the number of data bits. Then comes the parity and the last digit indicates the number of stop bits.
- Flow control Interface protocol

Network menu

- NPAP mode Whether the NPAP commands are used. When using MarkVision, the NPAP mode must be Auto or On.
- BootP Whether the TCP/IP protocol that enables a workstation to find its IP address is enabled or disabled for the network adapter
- IP address A unique address of the printer in the TCP/IP network environment
- IP netmask Bit mask that logically subdivides the network, specifying a local network portion of the IP address
- IP gateway A unique address of the equipment for the gateway to outside of the enclosed environment

Test menu

- PCL config page Print a self-test report using PCL emulation
- PCL font list Print a list of fonts available in PCL emulation
- FPS config page Print a self-test report using FPS emulation
- FPS font list Print a list of fonts available in FPS emulation

Clear warning

- <Clear warning> print unit Clearing the print unit counter

Handling Paper

Discusses paper selection and paper handling:

- Types and sizes of paper you can use with this printer, including envelopes and transparencies
- Ensuring that both the software program and the printer have compatible paper size settings
- Tips on handling print media
- Adjusting the paper tray to fit a different paper size
- Feeding paper manually

Paper Types and Sizes

This printer can print on a variety of common office papers in addition to standard photocopier bond. Bond paper can range in basic weight from 60 to 90 g/m² (16 to 24 pound) for the paper tray and from 60 to 105 g/m² (16 to 28 pound) for the manual feed slot. Smooth paper produces the best print quality, but textured papers usually provide satisfactory results.

The following descriptions also apply to an optional paper tray.



Notice:

When you use thick paper, follow these guidelines:

- When you are using thick paper or special paper and find improper adhering of toner to the paper, turn the thick paper mode on using the control panel. This mode is invalid for envelopes, transparencies, and labels.
 - Turn the mode off when you print on regular paper. Printing regular paper with this mode on may cause a decrease in print quality or reliability of the printer.
-

This printer can print on a wide range of paper sizes, but the size is limited when using paper trays.

- When using a paper tray, the size is:

Paper size (physical)	Dimensions
A4 (European letter size)	210 × 297 mm
A5	148 × 210 mm
Letter (US letter size)	8.5 × 11 in
Legal (US legal size)	8.5 × 14 in
Executive	7.25 × 10.5 in

- When using the manual feed slot, the size is:
 Minimum: 100 mm wide × 148 mm long (3.94 × 5.81 inches)
 Maximum: 216 mm wide × 360 mm long (8.5 × 14.13 inches)

- When using the MFF (option), the size is:

Paper size (physical)	Dimensions
A4	210 × 297 mm
A5	148 × 210 mm
Letter	8.5 × 11 inches
Legal	8.5 × 14 inches
Executive	7.25 × 10.5 inches
Envelope COM-10	4 1/8 × 9.5 inches
Envelope Monarch	3 7/8 × 7.5 inches
Envelope C5	162 × 229 mm
Envelope DL	110 × 220 mm
Envelope B5	176 × 250 mm



Notice:

When printing on legal-size paper in the FPS emulation, add RAM extension cards of 8M bytes or more (11M bytes or more in total) or select “banding mode on” (memory mode) in the FPS menu.

If a print job stops because of a certain error and the control panel LCD displays MEMORY SHORTAGE, take the same measures.

Although this printer can print on any sheet within the limits stated above, printing area and margin calculations are based on several paper sizes as shown in the table below. Use the control panel to change the supported paper size.

Paper size (logical)	Dimensions
A4	210 × 297 mm
A5	148 × 210 mm
Letter	8.5 × 11 inches
Legal	8.5 × 14 inches
Executive	7.25 × 10.5 inches
Envelope COM-10	4 1/8 × 9.5 inches
Envelope Monarch	3 7/8 × 7.5 inches
Envelope C5	162 × 229 mm
Envelope DL	110 × 220 mm
Envelope B5	176 × 250 mm

When the PCL emulation is used and if the physical paper size (tray size or MFF paper size) is different from the logical paper size (value specified by setup menu of paper size), a paper mismatch error occurs.

General Tips

Observe the following tips when handling print media.

- Do not use paper that is wrinkled or curled.
- Do not use paper with staples or metal parts.
- When printing both sides of sheets, we recommend you to use an optional duplex unit. If your printer has no duplex unit, use the manual feed slot and remove curls after first printing. Use paper in 105 g/m² (28 pound) weight. Paper thinner than this weight may be wrinkled thus causing decrease in print quality.
- Two-sided printing is not allowed for transparencies, envelopes, and labels even if your printer has the duplex unit.

Preprinted Sheets

In general, you can safely print on preprinted sheets such as letter-head. However, letterhead with thermographic (raised) printing, embossing, or foil stamping may not work well. The forces used to create these effects (heat and/or pressure) are also used in the printer's fuser unit. For this reason, the fuser unit may damage the preprinted image.

Load preprinted paper with the printed side facing down in the paper tray. When using the manual feed slot, place paper with the printed side facing up. For printing in portrait orientation, the letterhead should be at the front of the tray. For landscape orientation, it should be at the right of the tray. For more information on printing in different orientations, see the later section of this chapter.

Transparencies

This printer can print on overhead transparency material.

- We recommend you to set up the rear stacker (or that of the duplex unit when your printer has the duplex unit) so that transparencies are ejected straight out the back to minimize curl.

The capacity of the rear stacker is about 20 sheets.

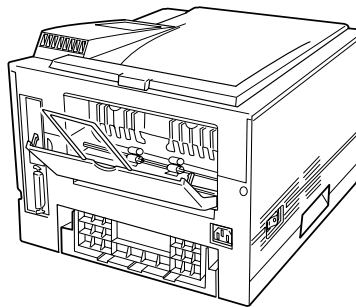

- Use materials specially designed for laser printers or photocopiers.
- Always feed transparency material from the multi-function feeder (MFF). Use the manual feed slot of the printer if the MFF is removed.
- To remove curls from printed transparency materials, use correct frames or put a weight on them until they lay flat.
- Be sure to fan the transparency stack to prevent sheets from sticking together.

Envelopes

This printer prints well on envelopes if you carefully follow these guidelines:

- Use envelopes made of paper in 75 to 105 g/m² (20 to 28 pound) weight. Printing with envelopes made of paper thinner than this weight may produce wrinkles thus causing decrease in print quality.
- Be sure to set up the rear stacker (or that of the duplex unit when your printer has the duplex unit) so that envelopes are ejected straight out the back to minimize curl.

The capacity of the rear stacker is about 20 sheets.

- Use the envelope sizes shown in the preceding table.
- To avoid damage to the printer, never use envelopes with clasps, snaps, windows, or synthetic materials.
- Feed from the multi-function feeder (MFF). Use the manual feed slot of the printer if the MFF is removed.
- Feed the envelopes with the gummed side of the flaps facing downward.
- Do not use “encapsulated” adhesives, which seal by pressure alone.
- To avoid jamming, restrict the minimum paper weight to 64 g/m² (17 pound).
- To avoid creasing along the edges, use high-quality envelopes with stiff edges.
- To avoid uneven printing, do not attempt to print on the gummed overlap areas.
- Be sure to feed or load the envelopes with the envelope centered against the manual feed slot. Use the guide of the paper sizes.
- Before attempting large-scale printing on envelopes, consult with your stationery dealer. Also, test the envelopes carefully for consistent, trouble-free printing.

Labels

This printer prints well on labels if you carefully follow these guidelines:

- Be careful to use labels under normal operating conditions. Labels are sensitive to temperature and humidity.
- Use the rear stacker (or that of the duplex unit when your printer has the duplex unit) so that labels are ejected straight out the back to minimize curl.
- Use only labels without backing sheets exposed in the printable area. Labels mounted separately on a backing sheet tend to slip, resulting in crooked print.

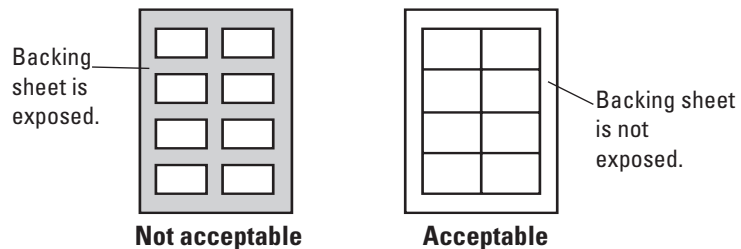

- Test-print labels before using them. If jamming problems occur and continue, try a different type of label.

Changing the Paper Tray Size

The paper tray can be adjusted to one of the three paper sizes: A4, A5, LTR (Letter), and EXE (Executive). If the paper tray is preset for one of these paper sizes at purchase, however, you cannot adjust it to the Legal size. To change the size, follow these steps:

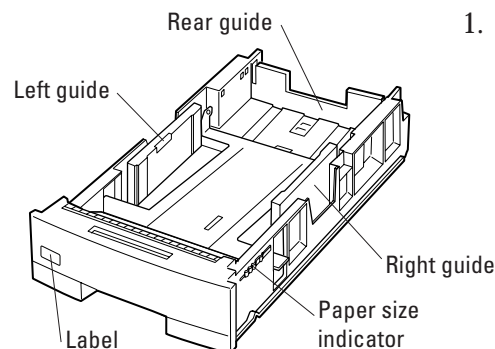

1. Remove the paper tray from the printer.

Refer to the illustration for the parts you adjust when changing the size of the tray.

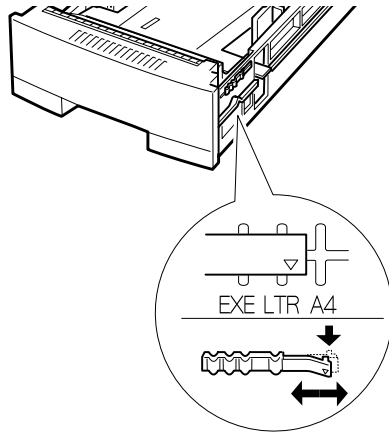

2. Change the setting of the paper size indicator. Lift the right end of the indicator and slide it to the desired position, that is, adjust the triangle mark to A4, A5, LTR, or EXE engraved on the tray.

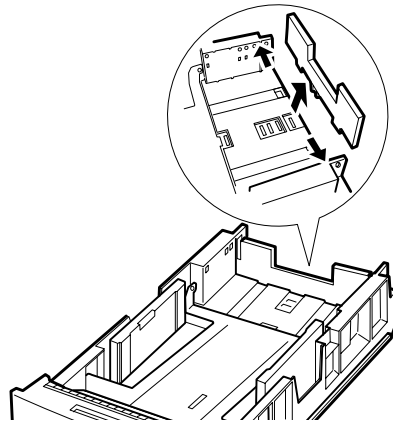

3. Remove the rear paper guide from the tray. Push the two catches inward to release the pins from the holes and remove the rear paper guide from the tray.

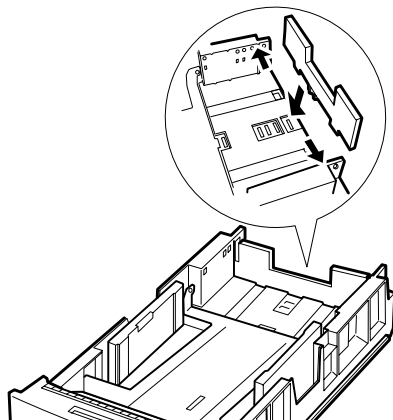

4. Attach the rear paper guide to the correct position. Refer to the label or engraving on the tray to locate the holes of the desired paper size.

Push the two catches inward to put the three projections into the bottom holes then the two pins into the side holes.

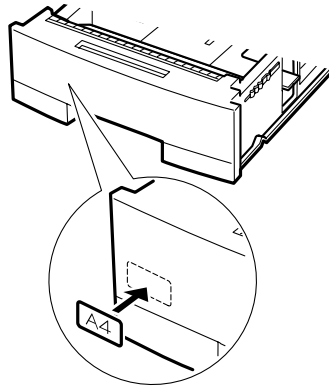

5. Adhere the correct paper size label.
6. Load paper and check that the paper fits the tray. Adjust the both side guides to the width of paper.
7. Return the paper tray. Slide the tray back into the printer.

PRINTING AND
PAPER HANDLING



Notice:

Select the correct paper size on the print menu of your application program, or a paper mismatch error will occur.

Using the Multi-function Feeder

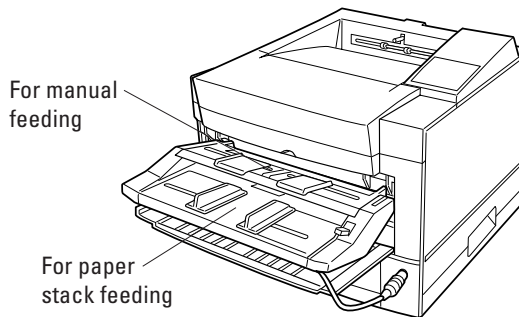

1. Adjust the left and right paper guides. The guides are separately provided for the manual feed path and the paper stack path.

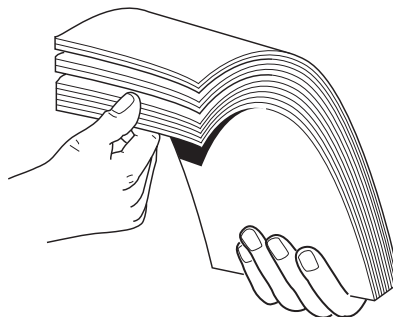

2. Fan the paper stack. When loading paper, be sure to fan the paper stack to prevent sheets from sticking together.

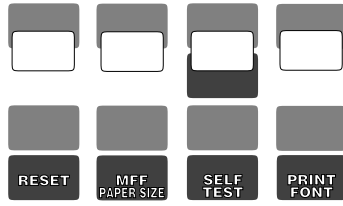

Feeding Paper Manually

The multi-function of this printer has a slot that allows you to feed sheets manually one by one. Use the manual feed slot to print a document on a different type of paper without unloading your regular paper from the paper tray. You also use manual feed for printing envelopes, overhead transparencies, and labels.

You can also use the manual feed slot built in the printer. The procedure is the same. In this case, remove the multi-function feeder from the printer as shown in the preceding page.

To use the manual feed slot, first select **MANUALFEED ON** using the tray select mode of the control panel. Next, start your software program to print a file. Then follow these steps:

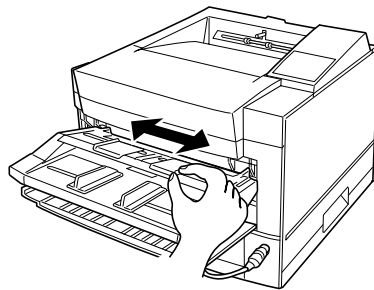

1. **Adjust the paper guides.** Position the left and right upper guides to the width of the sheet. (Lower two guides are for paper stack.)

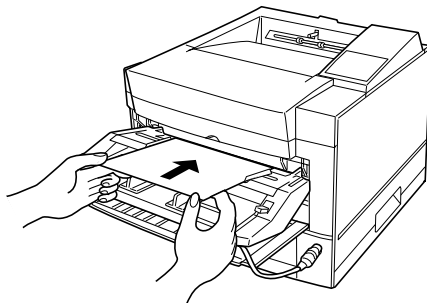

2. **Place the sheet with print side face up.** When the printer is ready to print, it displays the message **Insert size** to prompt you to prepare a sheet of paper. Insert the sheet until it is stopped by the feed rollers. Insufficient insertion prevents paper from being fed or causes skewed feeding.

Release the paper once it begins to feed automatically. If your file has additional pages, the printer prompts you for another sheet.

Setting Up the Rear Stacker

This printer has a rear stacker that allows you to eject sheets straight out the back to minimize curl. Use the rear stacker to print envelopes, overhead transparencies, and labels. For the rear stacker of an optional duplex unit, refer to its manual.

To use the rear stacker, follow these steps:

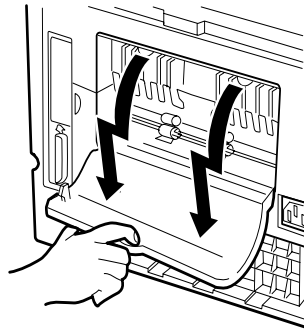

1. Open the rear stacker. Pull the projections at the top of the stacker.

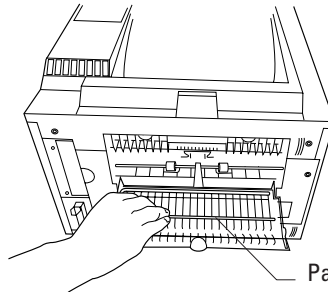

2. Remove the paper support from inside the stacker.

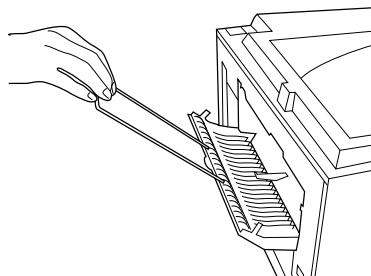

3. Set the paper support in position. Insert the two ends of the paper support into the mounting grooves of the rear stacker.

Printing on Nonstandard Size Paper and on Envelopes

Most of the control over printing on nonstandard size paper must come from your software program. Programs handle page size specifications in many different ways.

This section provides tips on feeding and using non standard paper with your Fujitsu printer.

Considerations on Paper Size

The following considerations apply:

- For envelopes and other nonstandard paper sizes, use the manual feed slot.
- Using the control panel, select a paper size that is equal to or *larger* than the physical size of the nonstandard size paper. Otherwise, part of the printed image may be cut off.

Selecting a paper size larger than the physical paper may result in data running off the edges of the paper. This can affect print quality and shorten the life of the print unit. To avoid this problem, adjust the page setup in your program so the print data falls within the limits of the physical page and center the paper in the manual feed slot.

Page Orientation

Figure 3-4 illustrates the two orientations and shows the relationship between the loaded paper and the resulting printout. This relationship is important if you want to print on letterhead. In portrait orientation, place the letterhead toward you and face down in the paper tray. In landscape orientation, place the letterhead against the right frame of the tray and face down.

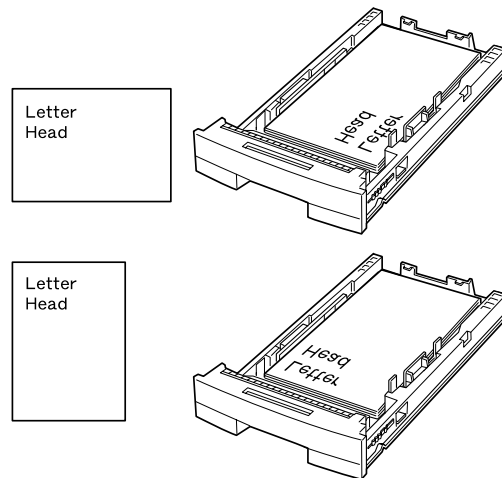

Figure 3-4 Portrait and landscape orientation

When using the manual feed slot, place the paper with its letterhead facing up. In portrait orientation, insert the paper with its letterhead away from you. In landscape orientation, insert the paper with its letterhead on the right hand side.

Some software programs allow you to print both portrait and landscape information on a single page. The function that allows you to do this is usually called something like “text rotation.” Consult your software documentation for information.

Enhancing and Customizing the Printer

This chapter explains the following ways to enhance or customize your printer:

- Add RAM up to a total of 64 megabytes except the resident RAM.
- Expand the fonts available from the printer.
- Add an additional interface to the Centronics parallel interface.
- Add a different size of paper tray.
- Add a paper feeder as the second paper source.
- Add a duplex unit as the two-sided printing mechanism.

You can order these options separately. See Appendix B for ordering information. Contact your dealer for information on other new options that may be available.

The following gives you brief information and installation instructions for each option.



Notice:

Be sure that the printer is turned off before installing an option.

Do not touch any connector contacts to avoid possible electrostatic damage to the printer.

Adding RAM

You may need to expand RAM to process more data for either of the following reasons:

- You commonly download several fonts when printing a job
- You print files with complex graphics

You can install two memory expansion cards. The expansion card can have 1, 2, 4, 8, 16, or 32 megabytes of RAM. Together with the printer's resident memory of 3 megabytes, these expansion options offer a range of RAM from 3 to 67 megabytes.

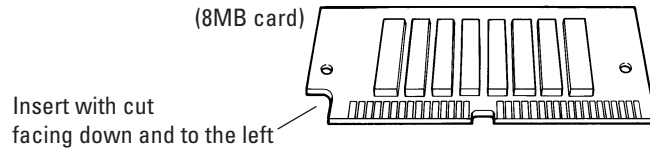

To install the RAM card, first make sure the printer is turned off and follow these steps:

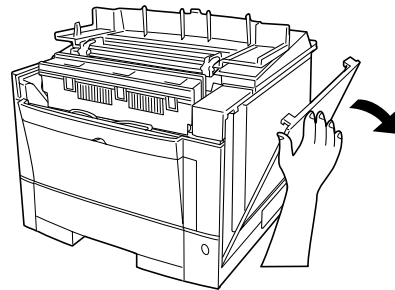

1. **Open the upper door and right side cover of the printer.** You will see a small cover on the metal plate. Remove the fastening screw and the cover. You can now see three connectors (upper two *ivory* ones for RAM cards).

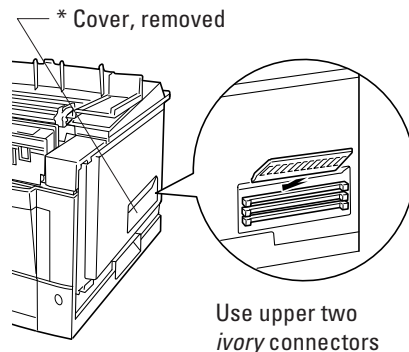

2. **Orient the RAM card.** Hold the card with the cut corner down and facing left and insert the card aslant into connector.



Notice:

Do not touch any connector contacts to avoid possible electrostatic damage to the printer.

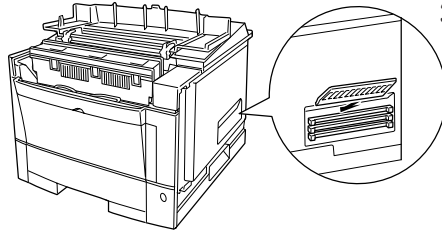

- 3. Install the RAM card.**
Push its top edge downwards so that holes of the card align with locating pins of the connector and the card is secured by retaining clips.

ENHANCING &
CUSTOMIZING



Important:

When installing two RAM cards, first install the lower one, and then the upper one.

Turn power on. If necessary, change buffer memory assignment (page protect or jam recovery) using the control panel.

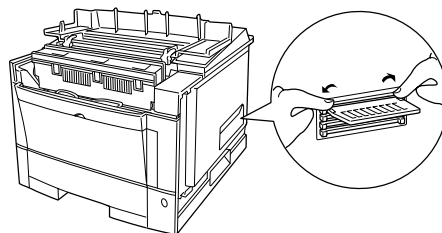

To remove an unsealed RAM card push out the retaining clips. When the card slants outwards pull the card to remove.

Installing an Interface Expansion Board

The printer's standard interface is parallel. The available optional interfaces are serial, LocalTalk, and Ethernet. If your computer cannot use a parallel port for your printer or the location of your printer is distant from the computer, you can use the serial port, LocalTalk port, or Ethernet port of the computer to connect your printer. Fujitsu offers the optional serial interface (RS-232C/422A) board, LocalTalk board, and Ethernet board C for these purposes.



Notice:

When sharing the printer among multiple computers, setting the I/O time-out short may cause a printing problem.

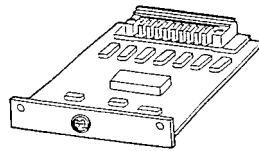

LocalTalk interface board

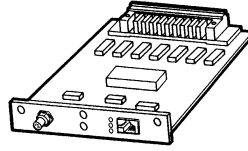

Ethernet interface board

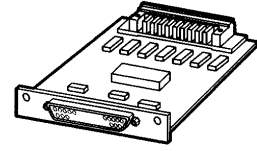

Serial interface board

Installing an Interface Board

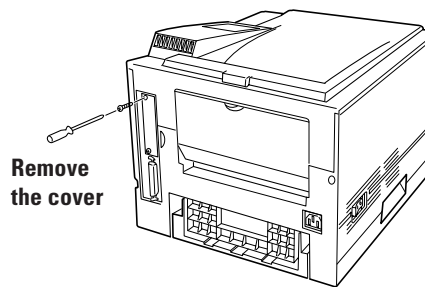

Remove the cover

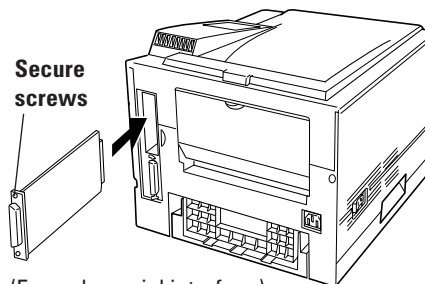

Secure screws

(Example: serial interface)

1. To install an interface board, first make sure the printer is turned off. Remove the interface board slot cover from the back right of the printer.
2. Hold the board with the parts mounting side left. Slide the board into the empty interface slot using the guides, and push it until it stops. Secure the board by the two screws supplied with it.

Connecting to the Serial Port

Connecting to the serial port involves the following tasks:

- Connect the interface cable to the printer and your computer.
- Print out the status report to check the serial parameter default settings.

Connecting the Serial Interface Cable

To connect to the serial interface port, you need a cable correctly wired for this printer and your computer. The cable must also have the proper connectors. Your dealer or technical support person can supply you with the proper cable.

The serial interface of this printer requires a null-modem cable with a male DB25 connector at the printer side. Refer to your computer documentation for the type of connector required by its serial port.



Notice:

Be sure that the printer is turned off before connecting the interface cable.

Do not touch any connector contacts to avoid possible electrostatic damage to the printer.

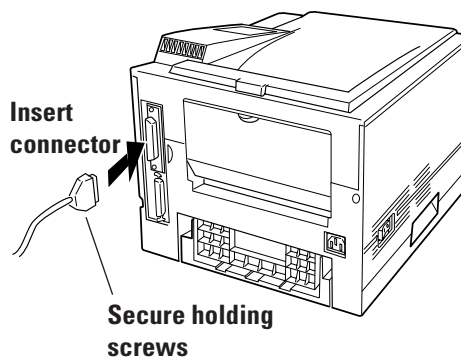

To make the connection, plug the cable connector into the serial interface port at the back right of the printer. Secure the connector by tightening the screws in the connector hood. Plug the other connector into your computer's serial port. Consult your computer documentation if you need help.

Selecting the Serial Interface

The printer's standard interface is parallel. When the serial interface board is installed, the printer automatically detects that the computer is using the serial interface.

Verifying Serial Parameter Settings

Next, you must make sure the serial parameter settings are the same between the computer and the printer. The reference manual explains the parameters. Consult your computer and software documentation to determine the settings your computer uses. Then compare these to the printer's settings in the following table.

Item	Parameter setting (default)
Baud rate	9600
Data bits	8
Stop bits	1
Parity	None
Flow control	DTR HI
Printer port	COM1

If the settings match, the installation is complete. If the interface parameters of the printer and the computer do not match, the message display indicates COMM. ERROR. The printer may not respond at all or it may print wrong characters. Change the settings in one of the two ways:

- Change options of the serial menu in setup mode.
- Set permanent defaults in your computer to match the printer's defaults.

On an IBM PC or compatible computer running MS-DOS, you can set permanent defaults by placing the following commands in your AUTOEXEC.BAT file:

```
MODE COM1:9600,N,8,1,P  
MODE LPT1:=COM1:
```

Also make sure that the file MODE.COM is in your boot directory. Then whenever you boot your computer, the computer will print through the serial port using the printer's settings.



Important:

For information on DOS files and commands, consult your DOS manual or the manual supplied with your computer.

Note that you may also be able to specify serial parameters through your software programs. Some software programs allow you to specify the printer port and serial settings from within the program. Consult the documentation supplied with the software.

Connecting to the LocalTalk Port

To connect to the LocalTalk port, simply connect the interface cable between the printer and your computer.

Connecting the LocalTalk Interface Cable

To connect to the LocalTalk interface port, you need a cable correctly wired for this printer and your computer. The cable must also have the proper connectors. Your dealer or technical support person can supply you with the proper cable.

For example, the LocalTalk Locking Connector Kit—DIN-8 (Apple product) is available. Also refer to your computer documentation for the type of connector required by its LocalTalk port.



Notice:

Be sure that the printer is turned off before connecting the interface cable.

Do not touch any connector contacts to avoid possible electrostatic damage to the printer.

To make the connection, firmly plug the cable connector into the LocalTalk interface port on the back right of the printer. Plug the other connector into your computer's LocalTalk port. Consult your computer documentation if you need help.

Selecting the LocalTalk Interface

The printer's standard interface is parallel. While the LocalTalk interface board is installed, the printer automatically detects that the computer is using the LocalTalk interface.

LocalTalk Specifications

The table below shows the physical specifications of the LocalTalk interface.

Specification	Description
The span of a single LocalTalk network	Max. 300 meters
Number of devices on a single LocalTalk network	Max. 32 devices
Speed of data transmission	230. 4K bits/second
Protocol	8 bit packet

Connecting to the Ethernet Port

The Ethernet interface board has two connectors, 10BASE-2 and 10BASE-T. The 10BASE-2 connector is for a coaxial cable, bus connection. The 10BASE-T connector is for a twisted-pair cable, star connection. Either will do.

Connecting to the Ethernet port involves the following three tasks:

- Check the type of cables your network uses.
- Select the 10BASE-2 or 10BASE-T connector of the interface board according to the connector type of your cable.
- Connect the interface cable to the printer and a network port.

Connecting the Ethernet Interface Cable

To connect to the Ethernet interface port, you need a cable correctly wired for your network. The cable must also have the proper connectors. Your dealer or technical support person can supply you with the proper cable.

For example, C66L-2810-0111 and C66L-1240-0002 (Fujitsu products) are available for 10BASE-T and 10BASE-2 ports respectively. Also refer to your network documentation for the type of connector required by its Ethernet port.



Notice:

Be sure that the printer is turned off before connecting the interface cable.

Do not touch any connector contacts to avoid possible electrostatic damage to the printer. For the same reason, do not remove the protective cover from the 10BASE-2 port which is not in use because you use the 10BASE-T port.

The procedure below applies to the 10BASE-2 port.

To make the connection, firmly plug the cable connector into the Ethernet interface port on the back right of the printer. Secure the connector by turning the connector hood. Plug the other connector into a network's Ethernet port. Consult your computer documentation if you need help.

Selecting the Ethernet Interface

The printer's standard interface is parallel. While the Ethernet interface board is installed, the printer automatically detects that the computer is using the Ethernet interface.

Ethernet Specifications

The table below shows the physical specifications of the Ethernet interface.

Specification	Description
The span of 10BASE-2	Max. 185 meters (coaxial, bus connection)
The span of 10BASE-T	Max. 100 meters (twisted-pair, star connection)
Speed of data transmission	10M bits/second

Adding Paper Sources

Paper Feeder

If you switch paper sizes frequently, you may want to add a second paper source. Or you may simply want to increase the paper capacity of your printer. You can easily do this by installing an optional paper feeder which consists of a base frame and a paper tray. The paper tray in the paper feeder is identified as *tray 2* and the one in the basic configuration is identified as *tray 1*.

The paper types and sizes used by *tray 2* are the same as those for the standard paper tray. The capacity is 500 sheets of 0.09 mm thick paper, twice that of the standard paper tray.

To install the paper feeder, follow these steps:

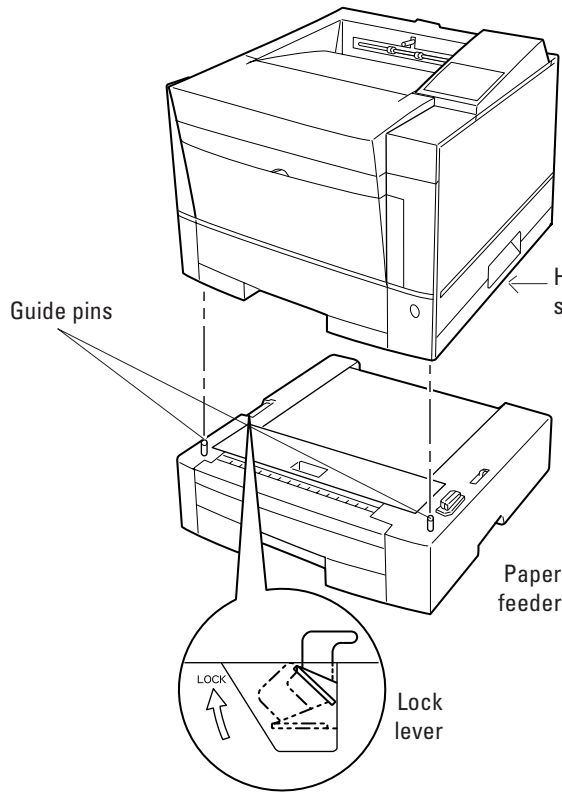

1. Turn off the printer and disconnect the power cord.
2. Make sure the lock lever is set to the open side. Push down the lever at the left side of the paper feeder.

3. Mount the printer on the paper feeder. Grip the bottom left and right sides of the printer to lift the printer and place it on the paper feeder. When placing the printer on the paper feeder, be sure you insert the two guide pins of the paper feeder into the two positioning holes at the bottom of the printer.

4. Set the lock lever to the lock side. Pull up the lever.

ENHANCING & CUSTOMIZING



Notice:

Be careful not to drop the printer on the paper feeder.

Do not touch any connector contacts to avoid possible electrostatic damage to the printer and paper feeder.

For paper loading, refer to **Loading Paper and Installing the Paper Tray** in Chapter 1. For paper sizes and types as well as tips on handling paper, refer to **Handling Paper** in Chapter 3.

Changing the Paper Tray Size

The paper tray can be adjusted to one of the four paper sizes: A4, A5, LTR (Letter), and EXE (Executive). If the paper tray is preset for one of these paper sizes at purchase, however, you cannot adjust it to the Legal size. To change the size, follow these steps:

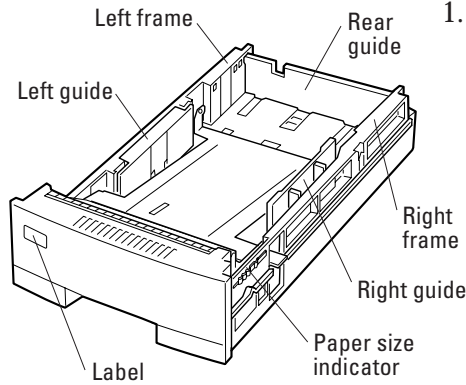

1. Remove the paper tray from the printer.

Refer to the illustration for the parts you adjust when changing the size of the tray.

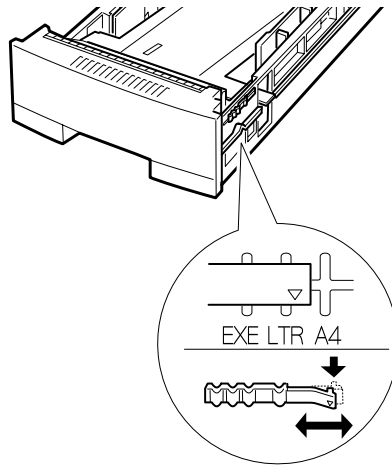

2. Change the setting of the paper size indicator. Lift the right end of the indicator and slide it to the desired position, that is, adjust the triangle mark to A4, A5, LTR, or EXE engraved on the tray.

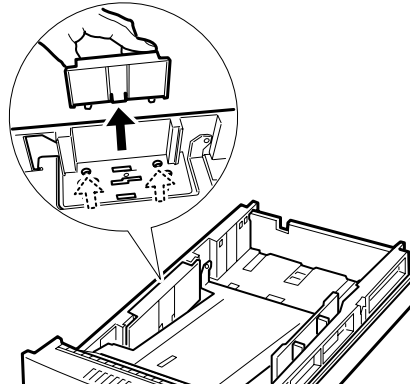

3. Remove the three paper guides from the tray. Unlock the guides as follows:

Left and right guides: Press the two catches inward.

ENHANCING &
CUSTOMIZING

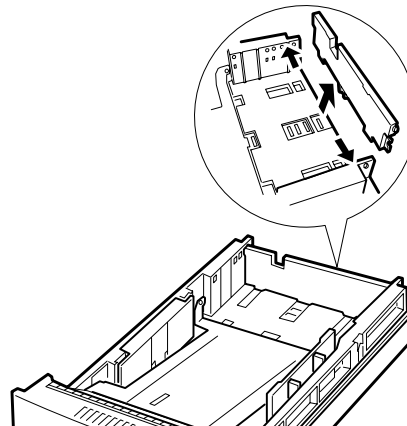

Rear guide: Push the end of the left or right frame outward and release the pin of the guide from the hole, then release the other pin.

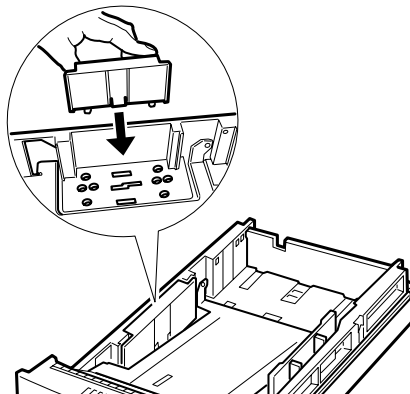

4. Attach the paper guides to the correct positions. Locate the mounting holes of the desired paper size by referring to the label or engraving on the tray.

Left and right guides: Put the two catches into the holes.

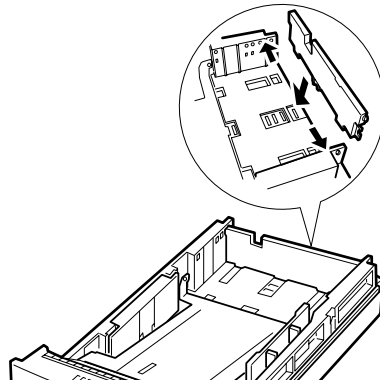

Rear guide:
Mount the guides in reverse
order of the removal.

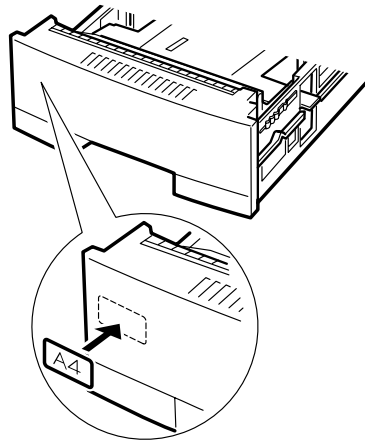

5. Adhere the correct paper size label.
6. Load paper and check that the paper fits the tray.
7. Return the paper tray. Slide the tray back into the printer.



Notice:

Select the correct paper size on the print menu of your application program, or a paper mismatch error occurs.

Different Paper Tray Sizes

The printer or paper feeder is shipped with a fixed size of paper tray. For example, it is the letter size for the USA and the A4 size for Europe. You can add different sizes of paper trays as shown in the following table. To install the paper tray, refer to **Loading Paper and Installing the Paper Tray** in Chapter 1.

Paper size	Dimensions
Letter (US letter size)	8.5 × 11 inches
Legal (US legal size)	8.5 × 14 inches
Executive	7.25 × 10.5 inches
A4 (European letter size)	210 × 297 mm
A5	148 × 210 mm

ENHANCING & CUSTOMIZING

Adding Duplex Unit

The duplex unit allows the printer to print data both sides of a sheet of paper. It can provide an extra margin for binding as specified by software.

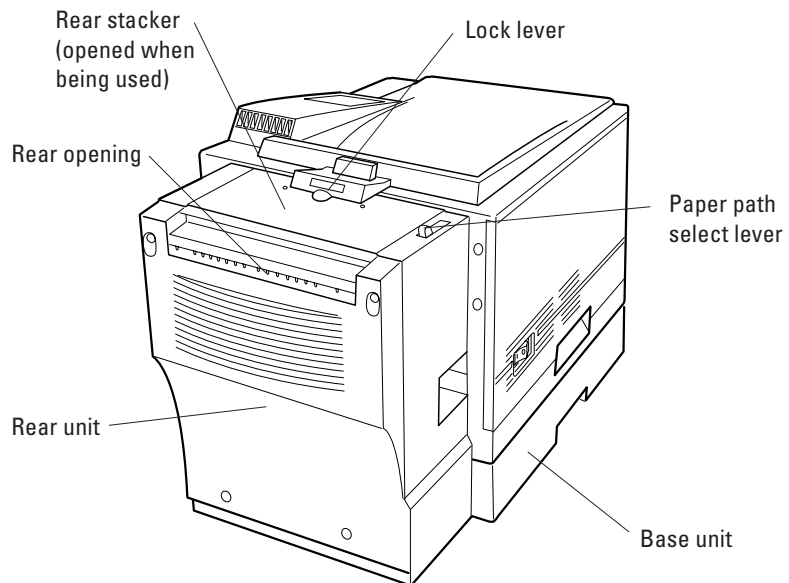

To print data using the duplex unit with the printer in the FPS emulation, the total capacity of printer's RAMs must be 10M bytes or more. Insufficient capacity restricts some functions.

To install and use the duplex unit, refer to its **User's Manual**.



Caution:

To avoid possible personal injury or harm to your equipment, cooperate with another person in assembling or disassembling the printer, duplex unit, multi-function feeder, and paper feeder (if installed). Do not lift or move the printer as equipped with other units.



Notice:

Be sure to keep the rear opening of the duplex unit away from a wall or another equipment so as to open the rear unit for clearing paper jam or not to block the reverse operation of paper that comes out and in the opening during two-sided printing.

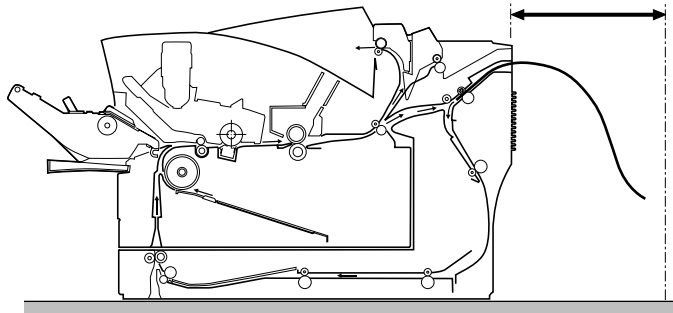

Maintenance

This chapter covers preventive maintenance, periodic routine maintenance, and repacking the printer for shipment or storage.

**Notice:**

Before performing any maintenance, be sure that the printer is turned off.

During maintenance procedures, do not touch any connector contacts to avoid possible electrostatic damage to the printer.

When performing maintenance, do not disassemble or remove any components unless specifically directed in the procedures.

Preventive Maintenance

The following guidelines can help to ensure trouble-free operation:

- Follow the guidelines in Chapter 1 when selecting a location for your printer.
- To minimize paper jams, store paper under favorable conditions. Do not expose paper to high humidity or moisture, which can cause wavy edges. Do not store paper in direct sunlight or allow it to become very dry, which can impart an electrostatic charge. Store paper flat, not on edge.
- If you must open the printer's upper door for more than three minutes, remove the print unit with the toner bottle mounted and store it in a dark place. Exposure of the photoconductor drum to light for more than three minutes can cause damage.
- Make sure small objects such as paper clips do not drop into the printer.
- When the message display indicates REPLACE PARTS, print a status report or display a <CLEAR WARNING> message in menu mode to confirm the cause of the message. For the procedures, see Chapter 3.
- Replace the toner bottle as soon as possible to prevent any dust from entering the print unit from the opening.
- Shake the toner bottle before installation.

Periodic Routine Maintenance

Table 5-1 lists the printer's periodic routine maintenance and indicates when this maintenance should be performed.

Table 5-1 Periodic Routine Maintenance

Maintenance	When to perform
Replace toner bottle and cleaner pad	When the message display indicates TONER LOW or TONER EMPTY, or when printing is too light
Replace print unit	When print quality is bad, even after replacing or cleaning other parts When the message display indicates <CLEAR WARNING> PRINT UNIT (Replace the print unit at the next replacement of the toner bottle)
Clean corona wire	When replacing the print unit or toner bottle, when printout shows vertical white lines, or when printing is too light
Clean paper path	When replacing the print unit or toner bottle, after clearing a paper jam, or when printouts show toner smudging
Clean precharger wire	When print density is uneven or when printing shows black vertical lines

Replacing the Toner Bottle and Cleaner Pad

The toner bottle and cleaner pad are packaged together as a toner kit and must be replaced at the same time. The cleaner pad is also available in a cleaner kit.

The toner bottle is designed to last approximately 5000 printed pages under the condition of 5% coverage on A4 paper or last about one year after unpacking. The first toner bottle may print slightly fewer pages.

Replace the toner bottle and the cleaner pad when the message display indicates TONER LOW or TONER EMPTY or when printing becomes lighter than you find satisfactory. After the toner low condition occurs,

you can only print about 20 more pages. Under the toner empty condition (no toner), the printer will not work.



Important:

Whenever you replace the toner bottle, clean the corona wire and the precharger wire to prevent a degradation in print quality.

You can continue to print after the toner low status if the print quality is still satisfactory. However, you must at least prepare a new toner bottle.

MAINTENANCE

To replace the toner bottle, follow these steps:

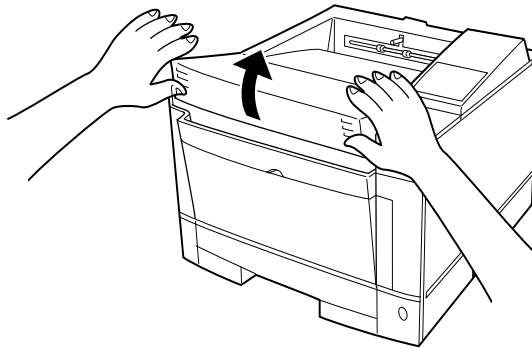

1. **Open the upper door.**
2. **Tap the toner bottle.** Tap the toner case to drop any remaining toner from toner bottle into print unit. This avoids the remaining toner from being spilt inside the printer during replacement.

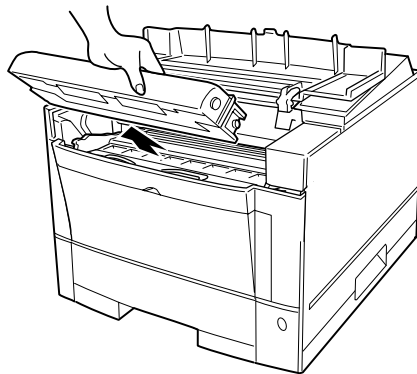

3. **Unlock and remove the old toner bottle.** Pull the top of the toner bottle toward you to swing bottle from the upright position to the removable position. Gently remove the bottle. If necessary, clean toner around the toner hopper entry of the print unit.



Notice:

Be careful not to allow dust or foreign matter into the toner hopper.

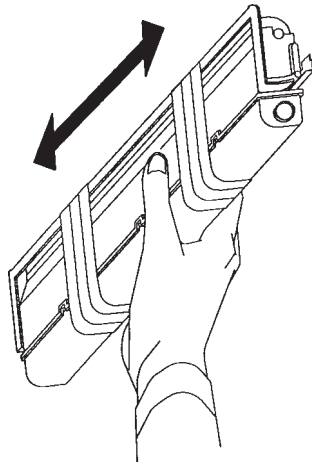

4. **Remove the toner bottle from its envelope.**
5. **Fully shake the toner bottle.**

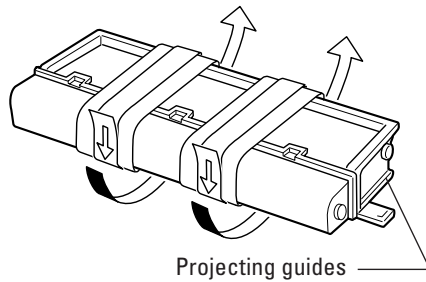

6. **Remove the plastic seal from the toner bottle.** Pull off the seal as gently as possible to avoid spilling toner. Handle the seal carefully to prevent staining your handles or clothes.

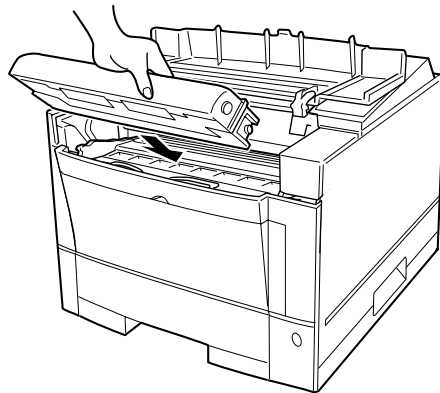

7. **Install the toner bottle.** Slide both projecting guides of the toner bottle along the grooves of the print unit.

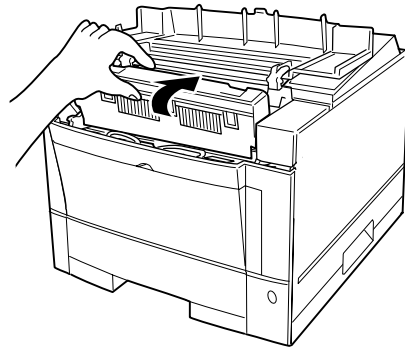

8. **Lock the toner bottle.** Push the toner bottle backward until it clicks into place.
9. **Close the upper door.**

MAINTENANCE



Notice:

Do not remove the toner bottle from the print unit until all the toner has been used in order to avoid scattering toner inside the printer.

To replace the cleaner pad, follow these steps:

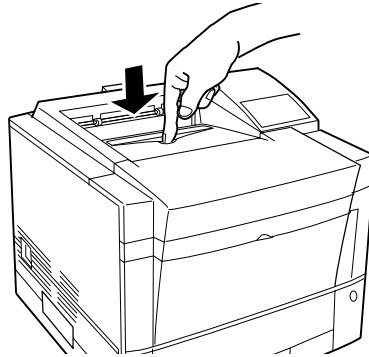

1. **Open the cover.** Push the engraved portion on the stacker to unlock the cover.

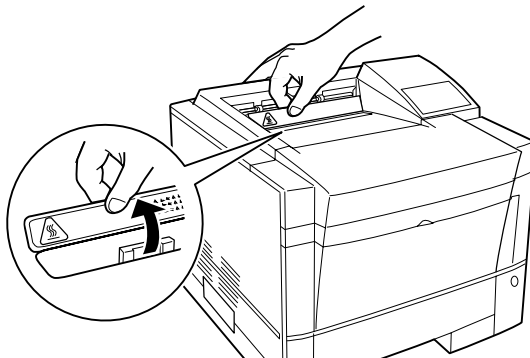

2. **Lift the front of the cover to open the cover.**

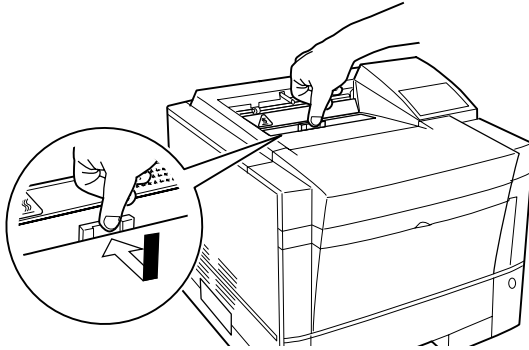

3. **Unlock the cleaner.** Push down the handle of the cleaner and push forward it to unlock the cleaner.

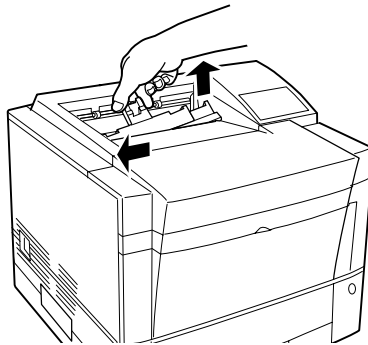

4. **Remove the cleaner.** Slide the cleaner to the left and take its right end out of the opening, and then the left end.

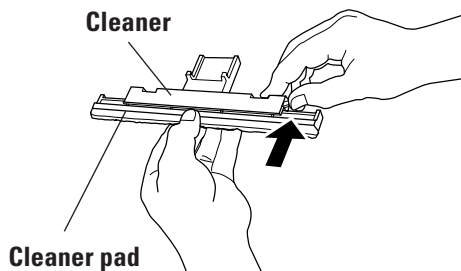

5. **Remove the cleaner pad from the cleaner.** Push the lock lever to unlock the cleaner pad.

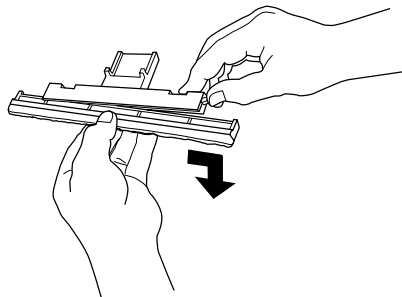

6. **Slide the cleaner pad to the right and separate it from the cleaner.**

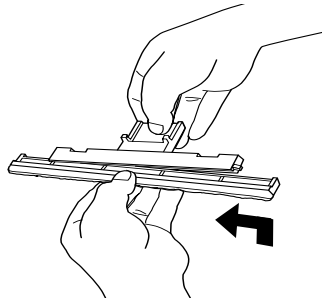

7. **Mount a new cleaner pad on the cleaner.** Put the new cleaner pad on the cleaner and slide the cleaner pad into the locked position.

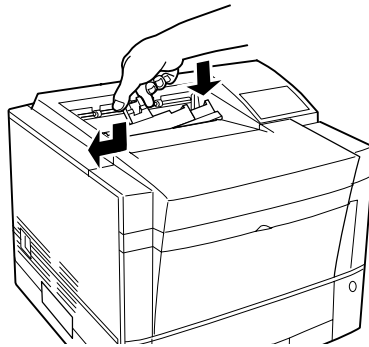

8. **Install the cleaner in the printer.** Grasp the handle of the cleaner and put the left end of the cleaner into the opening, and then the right end.

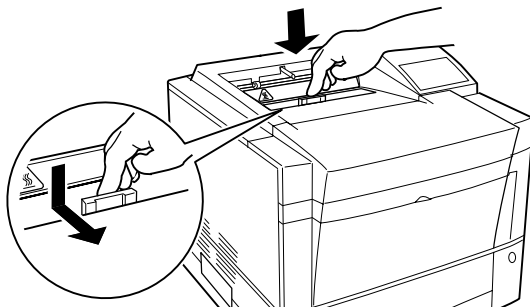

9. **Lock the cleaner.** Push down the top of the handle and pull it towards you to lock the cleaner.

10. **Close the cover.**

Replacing the Print Unit and Internal Cleaning

The print unit life is designed to last about 30,000 pages of 5% coverage continuous printing on A4 paper or about one year after unpacking, whichever comes first. The print unit life depends on print coverage, paper type, and operating and/or storage conditions. The print unit life ends when background smudge, ghosting, or dropouts occurs. Avoid unnecessary high coverage printing to maintain the print unit performance.

For the print unit life, this printer indicates the near end of life only. The printer message display begins indicating **REPLACE PARTS** when the print unit can print 3000 to 5000 more pages left. Prepare a new print unit if you notice this indication.

Even if the print unit reaches its near-end-of-life, use the print unit until its toner runs out (the message display indicates **TONER EMPTY**) for economy. After replacing the print unit, be sure to reset the print unit counter by using the control panel. For control panel operations, see the end of this section.

Replacing the print unit involves replacing the toner bottle. It is better to perform the following set of procedures when replacing the print unit:

- Remove the old print unit. (You cannot remove it from the printer after detaching the toner bottle from it.)
- Clean the paper path.
- Clean the corona wire.
- Install the new print unit, then the new toner bottle.

The following sections describe these procedures in the order listed.

Removing the Print Unit

Perform this procedure in the following cases:

- To replace the print unit
- To store the print unit in a clean, dark place when working inside the printer for more than three minutes



Caution:

For safety, turn off the printer and disconnect the power cord before beginning.

To remove the print unit, follow these steps:

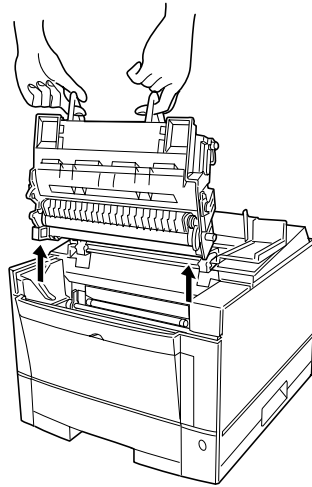

1. **Open the upper door.**
2. **Raise the green handles of the print unit.**
3. **Remove the print unit.**
Pull the green handles at a 45° angle toward the front of the printer. This will disengage the print unit, allowing easy removal.

MAINTENANCE

When the print unit begins to move, gently lift it up and out.

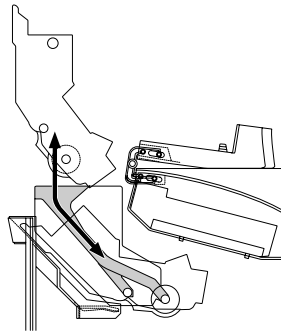

If you want to re-use the print unit, be careful not to scratch the green surface of the drum against the printer or its parts.



Notice:

If you want to re-use the print unit, do not touch or scratch the green drum surface after removing the print unit.

Print unit

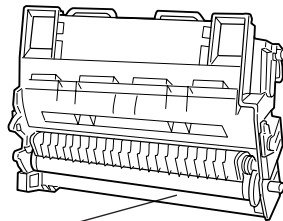

Green drum

To avoid spilling toner, be sure to keep the print unit upright and keep the toner bottle mounted on the print unit.

Cleaning the Paper Path

Clean the paper path:

- When replacing the print unit
- After clearing a paper jam
- When printouts show toner smudging



Notice:

If the print unit is still installed, complete this procedure quickly. You should avoid exposing the photoconductor drum to light for more than three minutes.

If you think you need more time, remove the print unit and store it in a clean, dark place. To remove the unit, see the preceding section **Removing the Print Unit**.

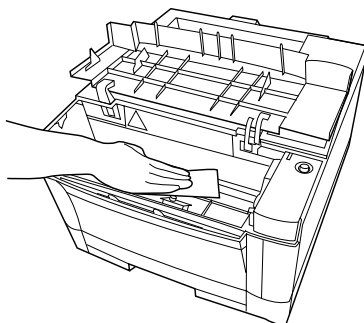

Open the upper door and remove the print unit. Be careful not to damage the green drum surface. Look for spilled toner on the inside of the printer. Use a damp cloth to remove any toner stains.

Cleaning the Corona Wire

The corona wire is located in the metallic housing (chrome frame) on the base frame inside the printer.

Perform this procedure:

- When replacing the print unit
- When the printout shows vertical white lines or printing is too light



Notice:

You should avoid exposing the photoconductor drum to light for more than three minutes.

Be careful not to break the corona wire.

Use the cleaning brush supplied with the printer. This L-shaped tool has two cleaning pads: one for the corona wire and the other for the precharger wire inside the print unit. Use the pad on the shorter branch.

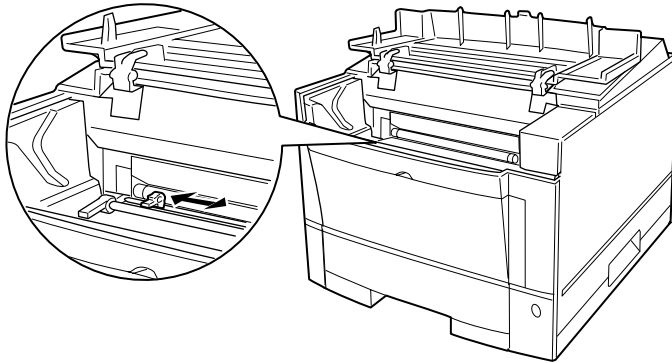

Remove the print unit and store it in a dark, level, steady place. Be careful not to damage the green drum surface. Using the tool as shown in this figure, clean the corona wire. Fit the positioning cut onto the wire housing frame and gently move the tool left and right two or three times along the length of the wire to remove any dirt or other substance. Be careful not to break or otherwise damage the wire.

MAINTENANCE

After you have cleaned the printer, install the print unit and close the upper door.

Cleaning the Paper Guide before the Corona Wire

Perform this procedure when printouts show small spots of toner smudging especially near the top edge of paper.

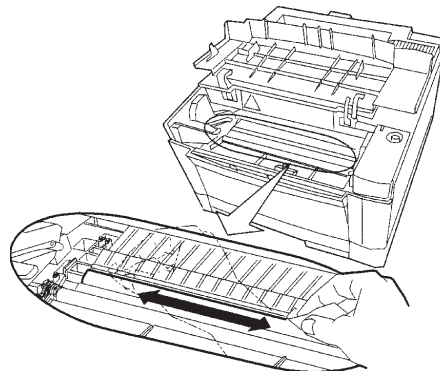

Open the upper door and remove the print unit. Be careful not to damage the green drum surface. Look for dust on the paper guide before the corona wire. Use a clean, lint free cloth to gently remove any dust from the entire surface of the paper guide.

Installing the New Print Unit



Notice:

To avoid exposing the photoconductor drum to light or contamination, follow these guidelines:

- Do not remove the print unit from its envelope until you are ready to install it.
- Complete the procedure as quickly as possible to avoid exposing the drum to light for more than three minutes.

To avoid damaging the drum:

- Be sure to remove the plastic sheets after installing the print unit. Operating the printer without removing the sheets will make the print unit unusable.
- Never touch or scratch the green drum surface.

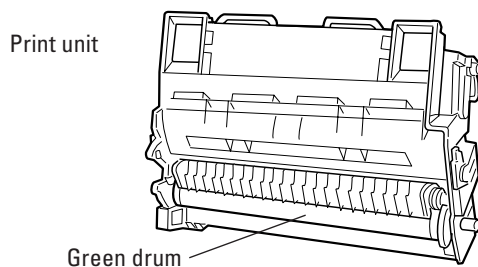

- Be careful not to allow dust or foreign matters into the toner hopper.
-

To install the new print unit, follow these steps:

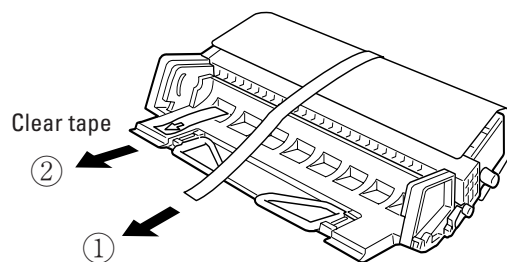

1. **Remove the print unit from its envelope.** Place the unit on a level, steady place.
2. **Remove the protective materials from the print unit.** Remove protective sheet ①. Pull narrow clear tape ② until its blue end is visible and remove it.

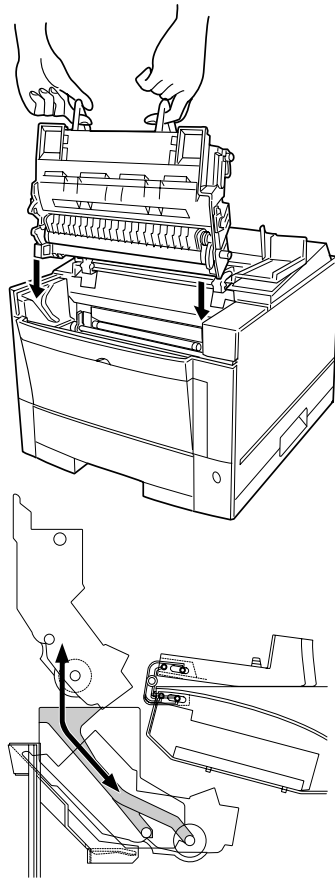

3. **Lower the print unit into the printer.** Grasp the print unit by its green handles with the green drum surface facing you.

First, slide the print unit straight down the ends of the drum shaft along the grooves on the sides of the printer. Then, slide the print unit at a 45 degree angle toward back of the printer.

When handling the print unit, never allow its green surface to touch anything, since it can be easily scratched.

MAINTENANCE

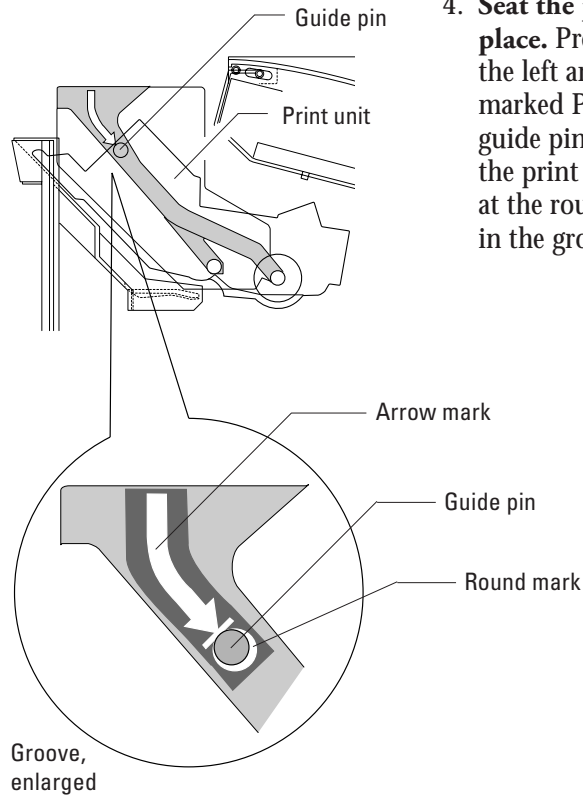

4. **Seat the print unit in place.** Press down gently on the left and right portions marked PUSH until the guide pins at both sides of the print unit are positioned at the round marks (labeled in the grooves).



Notice:

If you do not proceed to the next step immediately, close the printer's top cover to protect the photoconductor drum from light.

After you have installed the print unit, install the toner bottle. See **Replacing the Toner Bottle** described previously in this chapter.

Close the printer's upper door. Press down the top cover until it clicks shut. Reconnect the power cord and turn on the printer.

Resetting the Print Unit Counter

Perform this operation whenever you have replaced the print unit, or the printer continues displaying the warning message REPLACE PARTS.

To reset the print unit counter, follow these steps:

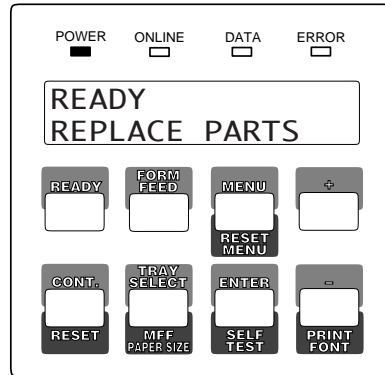

1. Make sure the printer is offline. If necessary, press the **READY** button to put the printer offline. The ONLINE indicator is off with the REPLACE PARTS message displayed.

MAINTENANCE

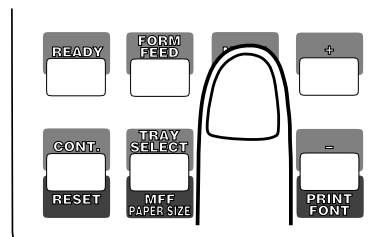

2. Press the **MENU** button to put the printer in menu mode.

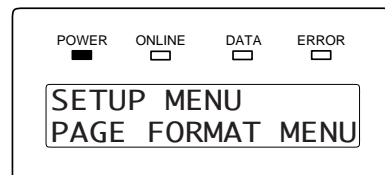

The message changes to SETUP MENU PAGE FORMAT MENU.

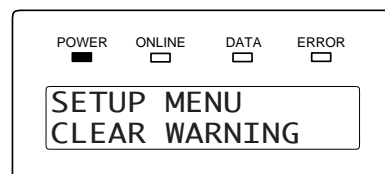

3. Press the **MENU** button repeatedly until the lower message changes to CLEAR WARNING.

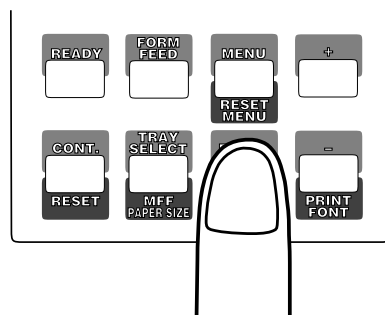

4. Press the **ENTER** button to select this function.

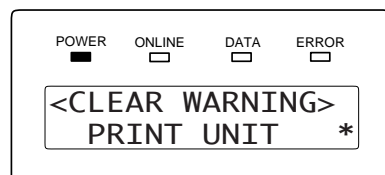

The message changes to <CLEAR WARNING> PRINT UNIT *. The asterisk means that the print unit is expired.

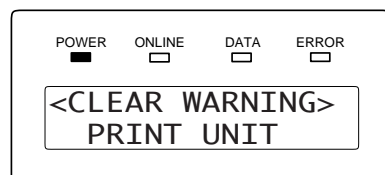

5. Press the **ENTER** button again to perform the function. The asterisk disappears from the message, indicating the counter is reset.

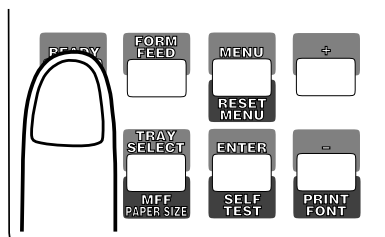

6. Press the **READY** button to return the printer online.

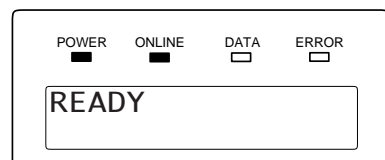

The ONLINE indicator lights up without the REPLACE PARTS message.



Important:

After the reset operation, check the status report to make sure that the Warning Message is cleared.

Cleaning the Precharger Wire

The precharger wire is on the print unit. Normally you should not need to clean this wire. However, the following conditions may indicate that the wire needs cleaning:

- Your printed pages have dark vertical lines, or the print density is uneven.
- Cleaning the corona wire does not solve the problem.

Use the cleaning brush supplied with the printer. This L-shaped tool has two cleaning pads: one for the precharger wire and the other for the corona wire inside the printer. Use the pad on the longer branch. To clean the precharger wire, follow these steps:

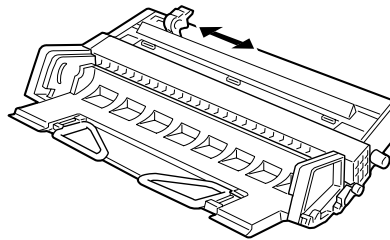

1. **Open the upper door of the printer.**
2. **Remove the print unit from the printer.** Place the unit on a level, steady place.
3. **Clean the wire.** To clean the wire, position the tool as shown in the figure, then gently slide it left and right two or three times along the length of the wire to remove any toner or other particles. Be careful not to break or otherwise damage the wire.



Notice:

- Avoid exposing the drum to light for more than three minutes.
- Do not touch or scratch the drum surface.

MAINTENANCE

Repacking the Printer

If you need to ship your printer or store it for an extended time, protect it by packing it in its original carton.

Store the print unit separately from the printer. Do not remove the toner bottle from the print unit. Cover the photoconductive drum to avoid exposing the drum to light, wrap the print unit and toner bottle with a protective material, and store it in a safe place.

To protect the printer from moisture, place it in the plastic bag it was shipped in. Seal the bag with tape.

Place the printer in its carton using the original packing materials to brace and protect the printer. The illustration shows the position of the printer components within the carton.

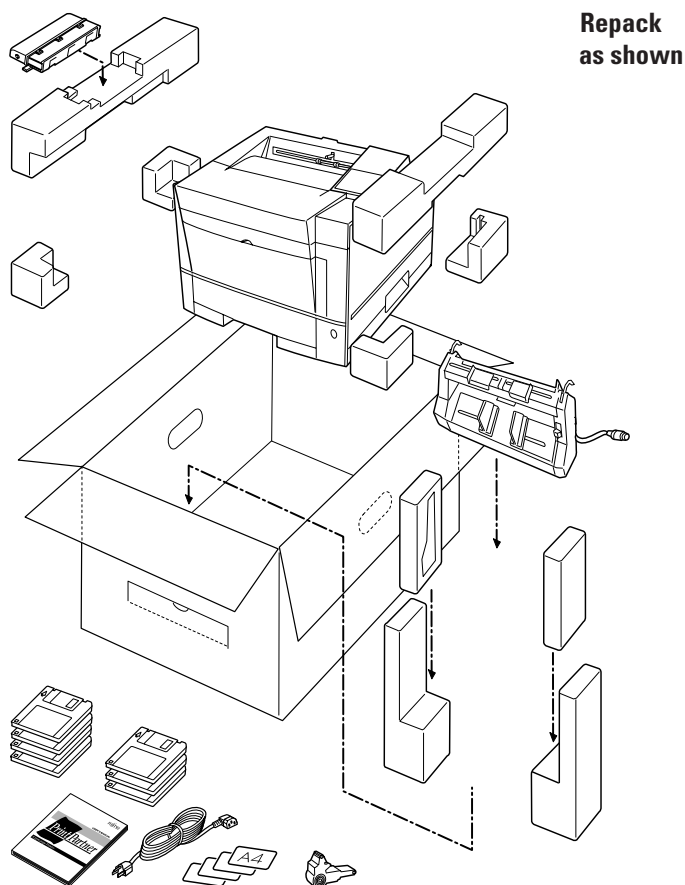

Solving Problems

Although this printer is designed to be highly reliable, you may occasionally experience problems. The most common problems are paper jamming and poor print quality. This chapter helps you to identify the cause of the problem and suggests solutions. For detailed procedures, see Chapter 5, **Maintenance**.

This chapter is divided into five sections:

- *Clearing Paper Jams*. This section explains how to locate and clear paper jams.
- *Operational Problems*. Start here if the printer doesn't function properly. You may save yourself a service call.
- *Print Quality Problems*. Check here if the printed pages don't look as they should.
- *Error Indications*. The printer has self-diagnostic tests for a variety of hardware and interface problems. If a test indicates a problem, the printer displays it on the control panel. This section explains these error conditions.
- *Printer Status Indications*. These statuses are not error conditions. Most of them require no action by you. However, explanations are included here for your information.



Notice:

During solution of a problem, do not touch any connector contacts to avoid possible electrostatic damage to the printer.

Clearing Paper Jams

The printer has sensors to detect paper jams. If a jam occurs, the printer displays it on the message display. The message is PAPER JAMn (*n*: 0 to 4 indicating the jam location). Because the paper path is short and simple, you should have no problem locating the jam.

To clear a paper jam, follow these steps:



Notice:

Clear paper jams quickly to avoid problems with the fuser unit.

Do not touch or scratch the green drum surface when clearing the paper jam.

Be careful not to expose the drum to light for more than three minutes.

Take special care when removing a jam from the transfer corona unit to avoid damage to the corona wire.

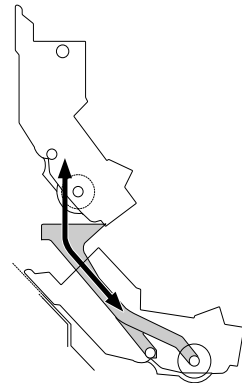
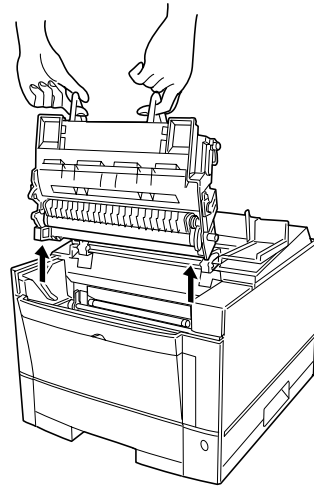

1. **Check the error message PAPER JAM n .** n indicates the position where the sheet has jammed. Follow the instructions shown below after step 3.

- $n = 0$ or 1, go to step 4a.
- $n = 2$, go to step 4b.
- $n = 3$, go to step 4c.
- $n = 4$, go to step 4d.

$n = 4$ appears when your printer is equipped with an optional duplex unit.

2. **Open the upper door.**
3. **Remove the print unit.** For detailed procedures and advisory notes, see the section **Removing the Print Unit** in Chapter 5.

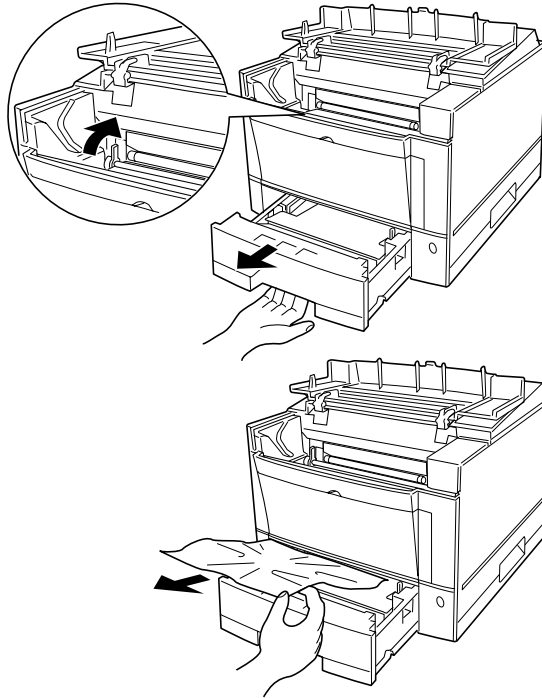

4a. Pull out the tray and raise the left and right levers of the feed roller.

Remove the sheet. Pull the jammed sheet gently not so as to remain pieces of paper in the printer.

After removing the sheet, return the two levers to their original positions (**pull the levers down toward you**).

SOLVING
PROBLEMS



Notice:

Leaving the two levers raised causes damage to the levers when the print unit is installed and pressed down.

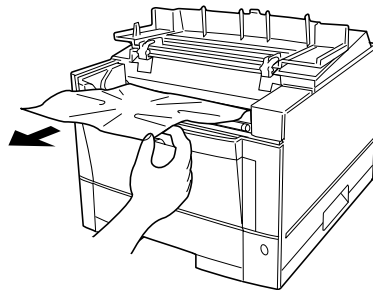

4b. Remove the sheet.



Caution:

Do not touch the heat roller. This hot area may burn your hand. See the label attached to the upper door.

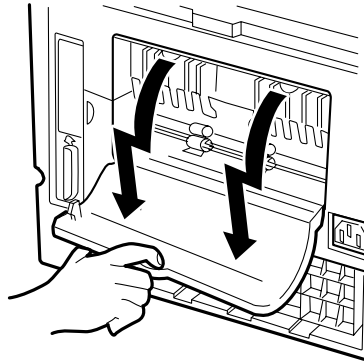

4c. Open the rear stacker at the back of the printer.

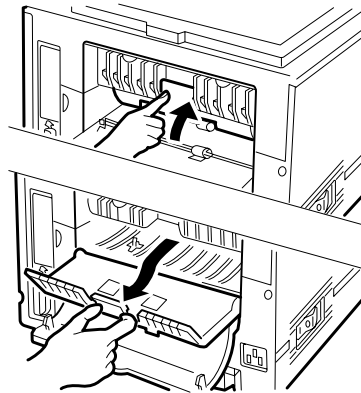

Draw out the paper guide.
First push up the top edge of the paper guide and then pull out the paper guide.



Caution:

Do not use the lever to pull out the paper guide. The lever or the paper guide may be damaged.

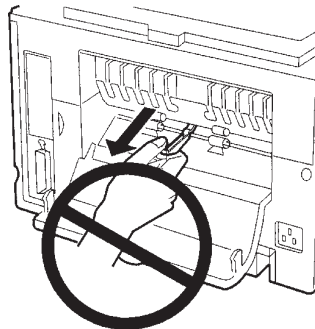

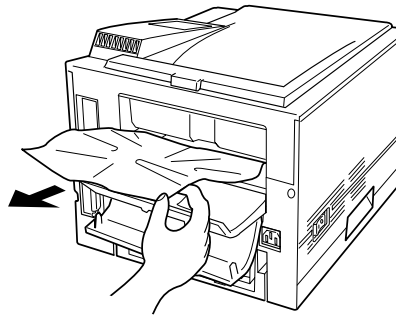

Remove the sheet. Pull the jammed sheet gently not so as to remain pieces of paper in the printer.



Caution:

Do not touch the heat roller. This hot area may burn your hand. See the label attached to the upper door.

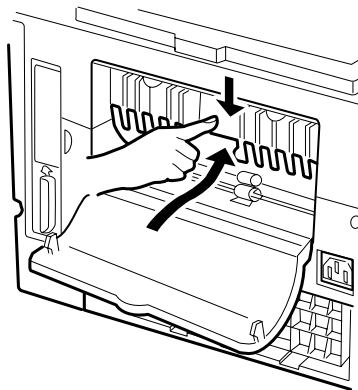

Return the paper guide to the original position. Raise the top edge of the paper guide and push down it to lock the paper guide in position.



Notice:

If the paper guide is not in the locked position, the printer will not work.

When your printer is equipped with an optional duplex unit, do not close the rear unit of the duplex unit with the paper guide of the printer drawn out. It may break the paper guide.

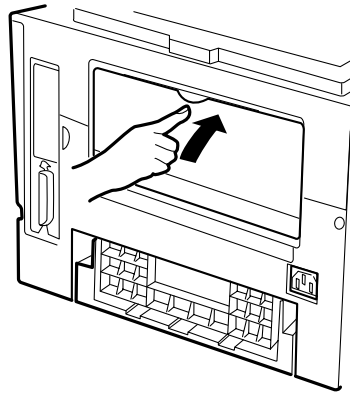

Close the rear stacker.

The following procedure is when your printer is equipped with an optional duplex unit. Be familiar with the paper paths in duplex printing.

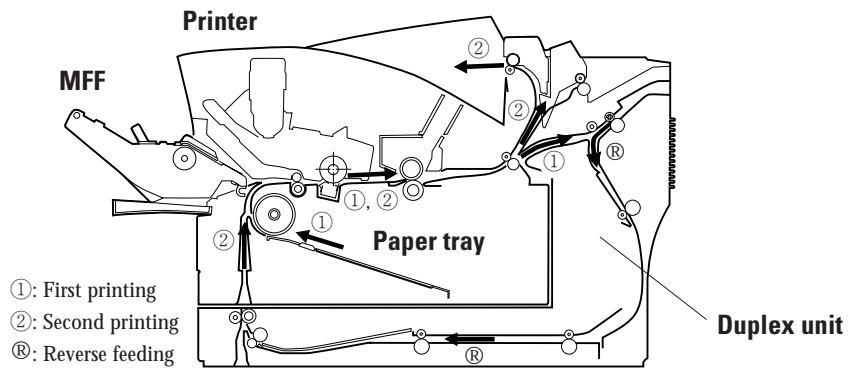

- ①: First printing
- ②: Second printing
- Ⓜ: Reverse feeding

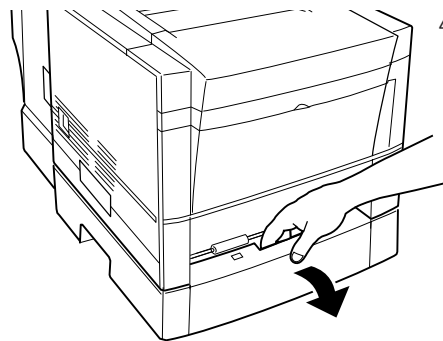

4d. Open the front door of the duplex unit. Pull out tray 1 and grasp center of the front door to unlock the door.

Pull the door towards you to open it.

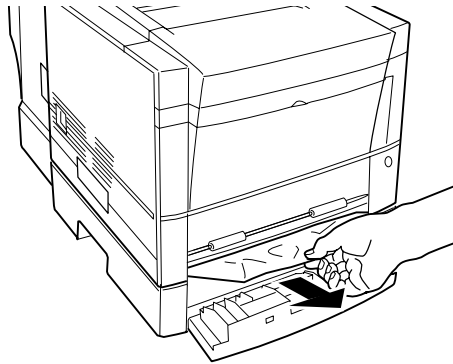

Remove the sheet. Pull the jammed sheet gently not so as to remain pieces of paper in the printer.

After removing the sheet, close the front door..

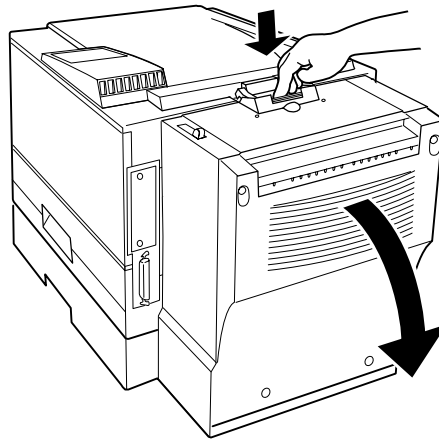

Open the rear unit of the duplex unit. Push down the lock lever of the rear unit and pull the door gently towards you.

SOLVING
PROBLEMS



Notice:

Do not open the rear unit forcibly to avoid damage to the hinge of the duplex unit.

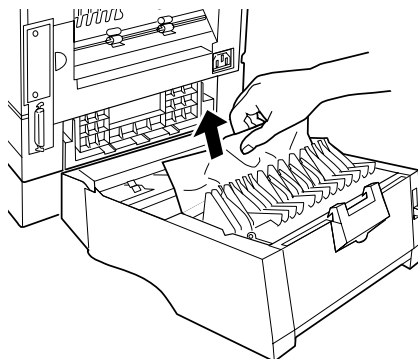

Remove the sheet. Pull the jammed sheet gently not so as to remain pieces of paper in the printer or duplex unit.

If necessary, draw out the paper guide of the printer.

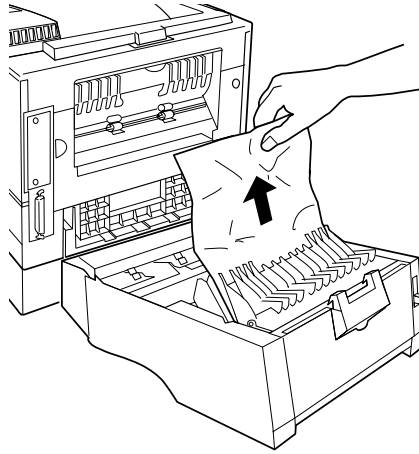

Close the rear unit. After removing the sheet, close the rear unit until its lock latches. Be sure to return the paper guide to the original position if it is drawn out.



Notice:

Do not close the rear unit of the duplex unit with the paper guide of the printer drawn out. It may break the paper guide.



Caution:

Be careful that your fingers or hair is not caught between the printer and the duplex unit when closing the rear unit.

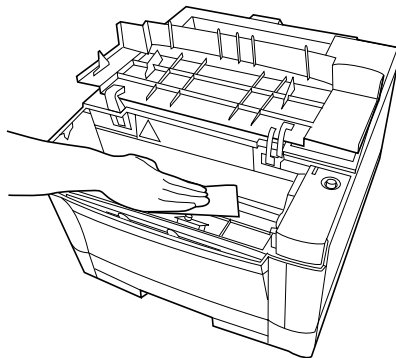

- 5. Clean the inside of the printer.** Look for spilled toner inside the printer. Clean away any toner with a damp cloth.

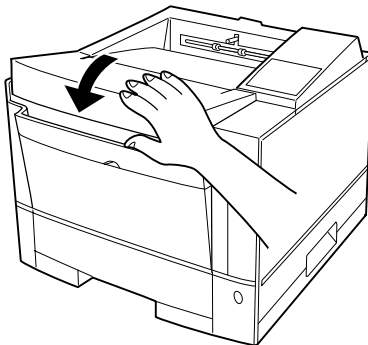
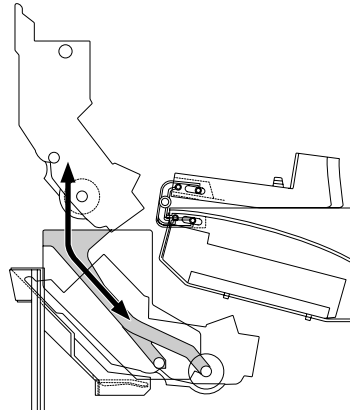
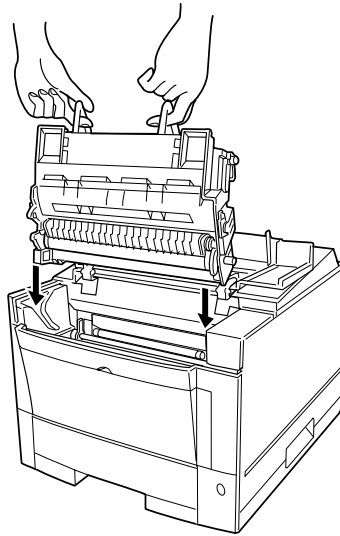

6. Install the print unit.

Grasp the print unit by its green handles with the green drum surface facing you.

First, slide straight down the ends of the drum shaft along the grooves on the sides of the printer. Then, slide the print unit at a 45 degree angle towards the back of the printer.

Press down gently on the left and right portions marked PUSH until the print unit snaps into position.

SOLVING
PROBLEMS

7. Close the upper door.

Before closing the door, make sure the print unit is seated properly. Press down the door until it clicks into place.

The table below contains advice on dealing with repeated paper feed problems.

Problem	Causes and solutions
Paper does not feed cleanly from paper tray	<p>Top edge of paper stack may be deformed (wavy or bent sheets). Try turning the paper stack around.</p> <p>Paper stack may not be aligned properly. Pull out the tray, straighten the paper stack against the paper guides, and re-insert the tray.</p> <p>Too many sheets in the paper stack. Make sure the stack is level with or below the limit mark on the left paper guide.</p> <p>The paper pressure plate may not be released. Pull out the tray and insert the tray again until it clicks up.</p>

Operational Problems

Problem	Solutions
No power when you turn on the printer	Check that the power cord is plugged in at both ends and that the power outlet has power.
Printer does not initialize	Close the upper door completely. Push down (lock) the paper guide (inside the rear stacker) in position.
Printer initializes, but does not online	Install a print unit. Insert the paper tray all the way.
Printer initializes, but the settings are wrong	Use the control panel to select the desired settings.

Print Quality Problems

The most common cause of poor print quality is the dirty corona wire or precharger wire. A rare cause is the expired fuser unit. The figures below show the typical appearances.

Due to dirty corona wire

Too light



White vertical line

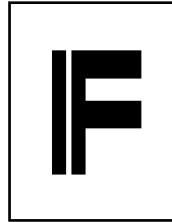

Ghost printing

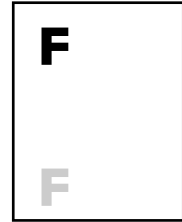

SOLVING PROBLEMS

Due to dirty precharger wire

Clear black vertical line

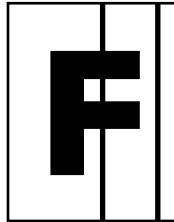

Toner stains (back)

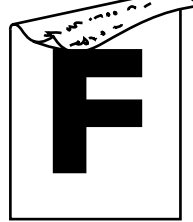

Due to both

Smudging

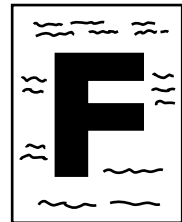

Due to expired fuser unit

Blurred black vertical line

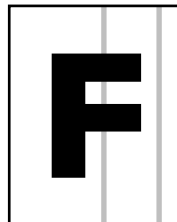

Problem	Solutions
Printing is too light	Turn the print density dial clockwise. Check to see if your paper is wet. Remove the print unit and rock it to distribute the toner evenly. Clean the corona wire.
Printing is too dark	Turn the print density dial counter-clockwise.
Page is black	Clean the precharger wire. Replace the print unit.
Page is blank	Clean the corona wire. Replace the print unit.
Vertical density is uneven	Clean the corona wire. Clean the precharger wire.
Vertical white lines appear	Remove the print unit and rock it to distribute the toner evenly, or replace the print unit. Clean the corona wire.
Vertical clear black lines appear	Clean the precharger wire.
Vertical blurred black lines appear	Clean the precharger wire. Contact your dealer if the fuser unit is damaged.
Ghost printing	Print several pages if this problem occurs after a paper jam. Clean the corona wire. Check to see if your paper is wet. Contact your dealer if the fuser unit is damaged.

Problem	Solutions
Pages have toner stains or smudging	If this problem occurs after a paper jam, print several pages. Clean the paper path. Clean the paper guide before the corona wire. Clean the corona wire. Replace the cleaner pad. If the fuser unit is damaged, contact your dealer.
Toner insufficiently adheres to or easily comes off paper when you are printing thick or special paper.	Turn the thick paper mode on using the control panel .
Vertical lines appear in solid black printing, stains appear in the back of a page, or paper is wrinkled or curled.	Check if the thick paper mode is on by using the control panel; if the mode is on, turn it off.

SOLVING PROBLEMS

Error Indications

Errors refer to a problem or condition which requires you to take action. The printer shows errors by using the ERROR indicator and the message display of the control panel. The following table lists the error indications, explains causes, and suggests solutions.

Message	Causes and solutions
BD CYCLE ERROR	Cause: Malfunction in the laser unit Solution: If the error recurs, consult your dealer for service.
COMM. ERROR	Cause: Communication error Solution: Press the [CONT.] button and select the correct settings of the serial interface using the control panel setup mode.

Message	Causes and solutions
COVER OPEN 1	Cause: Incomplete closing of upper door Solution: Close the upper door. Note: See caution following in this table.
COVER OPEN 2	Cause: Incomplete locking of paper guide inside the rear stacker Solution: Lock the paper guide. Note: See caution following in this table.
COVER OPEN 3	Cause: Incomplete closing of rear unit of the optional duplex unit. Solution: Close the rear unit of the duplex unit.
FUSER FAILURE	Cause: Malfunction in the fuser unit Solution: If the error recurs, consult your dealer for service.
INVALID SIMM	Cause: Incorrect SIMM card (optional emulation or font) installed Solution: Press the [CONT.] button.
JOB TIMEOUT	Cause: FPS job timeout (This error occurs when the FPS card is installed.) Solution: Press the [CONT.] button.
LOAD MFF size LOAD TRAYn size	Cause: Paper mismatch occurred. Solution: Set the specified tray to the correct paper size specified.
MANUAL TIMEOUT	Cause: Paper was not inserted into the manual feed slot in the prescribed time. (This error occurs when the FPS card is installed.) Solution: Press the [CONT.] button.
MEMORY OVER FLOW	Cause: Memory overflow error Solution: Press the [CONT.] button.
MEMORY SHORTAGE	Cause: Insufficient memory Solution: Add RAM board.
MFF NOT INSTALL	Cause: No MFF installed Solution: Install the MFF.

Message	Causes and solutions
MOTOR FAILURE n	Cause: Malfunction in the feed motor, etc. Solution: If the error recurs, consult your dealer for service.
NO PROCESS UNIT	Cause: No print unit is installed. Solution: Install the print unit.
OVERRUN ERROR	Cause: Incomplete in extracting compressed data Solution: Press the [CONT.] button.
PAPER JAMn	Cause: Paper jam in the specified position Solution: Clear the jammed paper from the following area: 0: Pick roller, 1: Entry to paper path 2: Paper path, 3: Ejection from paper path 4: Duplex unit
PS ERROR mn	Cause: A PostScript error Solution: If the error recurs, consult your dealer for service.
Source PAPER OUT	Cause: Paper out in the specified paper source Solution: Supply paper.
STACKER FULL	Cause: Paper stacker full Solution: Remove paper from the paper stacker.
SYSTEM ERROR n	Cause: A system error on the controller board Solution: If the error recurs, consult your dealer for service.
TRAYn MISS SET	Cause: Paper tray installed incorrectly Solution: Install the paper tray.
TONER EMPTY	Cause: Toner runs out. Solution: Replace toner bottle and heat roller cleaner.

Action-required Status Indications

These conditions, not errors, require you to take action. The following table lists the message indications, explains causes, and suggests solutions.

Message	Causes and solutions
INSERT size	Cause: Printer is ready for paper. Solution: Put paper into manual feed slot.
READY TONER LOW	Cause: Toner runs short. Solution: Prepare new toner bottle.
READY REPLACE PARTS	Cause: Print unit is near end. Solutions: Replace print unit. Note: Enter menu mode and select Clear Warning. After replacement, be sure to press ENTER to perform Clear Warning.



Important:

If the upper door is not firmly closed or the paper guide is not in the locked position, the printer does not work.

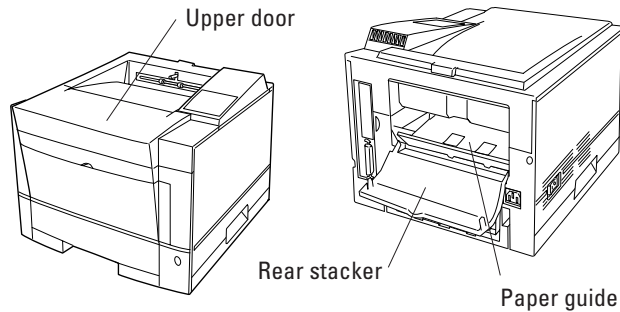

Printer Status Indications

Printer statuses refer to conditions which generally require no action by you. The following table lists the printer statuses and explains their meaning. It does not include messages in menu mode.

Message	Meaning
FORM FEED	The printer displays this message when you press FORM FEED with the DATA indicator off. The printer is printing data remaining in buffer.
<<<INITIALIZE>>>	The printer is initializing. This message appears whenever you turn on the printer, close the upper door, or lock the paper guide.
MENU RESET	The printer displays this message when you press RESET MENU for five or more seconds. This reset returns parameter settings in the menu to their factory defaults except for interface settings as well as clears error latches, buffered data, and temporary soft fonts.
PRINT FONT	The printer displays this message when you press PRINT FONT for five or more seconds. The printer is printing the font report.
READY	The printer is ready to print.
RESET	The printer displays this message when you press RESET for five or more seconds. This reset clears error latches, buffered data, and temporary soft fonts.
SELF TEST	The printer displays this message when you press SELF TEST for five or more seconds. The printer is printing the status report.
WARMING UP	The printer is warming up to its operating temperature.

SOLVING PROBLEMS

Warning Messages

This printer counts the number of the printed sheets to estimate the life of the consumables (print unit). The printer indicates the following warning message when and after the count reaches a predetermined value.

READY REPLACE PARTS

When the warning message is indicated, press the **READY** button to put the printer offline and press the **MENU** button to enter menu mode. The Clear Warning message appears, indicating the expired unit by an asterisk. When the print unit is expired, the message is:

<CLEAR WARNING> PRINT UNIT*

However, depending on the print quality, you may not have to replace print unit because you may suit be satisfied with the print quality.

Font Samples

This appendix provides scanned print samples of the fonts resident in this printer. Resident fonts are provided separately for two emulation modes:

- PCL mode
- FPS mode

PCL Mode

Bitmapped Font

Line Printer

Scalable Intellifonts

Courier

CG Times

CG Times Bold

CG Times Ital

CG Times Bd.Ital

CG Omega

CG Omega Bold

CG Omega Ital

CG Omega Bd.Ital

Coronet

Clarendon Cond.

Univers

Univers Bold

Univers Ital

Univers Bd.Ital

Univers Cond.

Univers Bd Cond.

Univers Cond.Itl

Univers Bd Cd It

Antique Olive

Antique Olive Bd

Antique Olive It

Garamond Antiqua

Garamond Halbfet

Garamond Kursiv

Garmnd Krsv Hbft

Marigold

Albertus

Albertus Extr Bd

Courier Bold

Courier Italic

Courier Bd Ital

Letter Gothic

Letter Gothic Bd

Letter Goth Itl

Scalable TrueType Fonts

Arial

Arial Bold

Arial Italic

Arial Bold Ital

Times New

Times New Bold

Times New Italic

Times New Bd Itl

Συμβολ

⌘ ⌘ ■ ⌘ ⌘ ⌘ ⌘ ⌘ ⌘ ⌘ ⌘

FPS Mode

Courier

Courier-Bold

Courier-BoldOblique

Courier-Oblique

Helvetica

Helvetica-Bold

Helvetica-BoldOblique

Helvetica-Oblique

Helvetica-Narrow

Helvetica-Narrow-Bold

Helvetica-Narrow-BoldOblique

Helvetica-Narrow-Oblique

Times-Roman

Times-Bold

Times-BoldItalic

Times-Italic

Symbol

Palatino-Roman

Palatino-Bold

Palatino-BoldItalic

Palatino-Italic

NewCenturySchlbk-Roman

NewCenturySchlbk-Bold

NewCenturySchlbk-BoldItalic

NewCenturySchlbk-Italic

AvantGarde-Book

AvantGarde-Demi

AvantGarde-DemiOb

AvantGarde-BookOb

Bookman-Light

Bookman-Demi

Bookman-DemiItalic

Bookman-LightItalic

ZapfChancery-MediumItalic

ZapfDingbats

Supplies and Accessories

This appendix provides ordering information on supplies required for periodic maintenance as well as optional accessories.

Contact your dealer to order or obtain additional information about the supplies and accessories listed here.

Supplies

Part name (order number)	Description
Toner kit (CA04040-C730)	The toner kit contains two toner bottles and two cleaner pads.
Print unit (CA02758-C400)	The print unit consists of a photoconductor drum, a developing unit, and a drum cleaner in a single module.

SUPPLIES AND
ACCESSORIES

Accessories

Part name (order number)	Description
Memory expansion cards (*1) (CA02417-C851) (CA02417-C852) (CA02417-C854) (CA02417-C858) (CA02758-C856) (CA04040-C853)	Allows RAM expansion by one of the following: 1 megabyte 2 megabytes 4 megabytes 8 megabytes 16 megabytes 32 megabytes

Part name (order number)	Description
Serial interface board (CA04040-C801) LocalTalk board 2 (CA04040-C826) Ethernet board C (CA04040-C832) (CA04040-C833)	RS-232C/422A AppleTalk compatible NetWare & TCP/IP corresponding For USA and UK For Europe
Paper trays (CA04040-C70x) (CA02758-C73x)	Adjustable for a different size 550 sheets (for tray 1) 1: A4, 2: Letter, 3: Legal 500 sheets (for tray 2) 1: A4, 2: Letter, 3: Legal 4: Executive, 6: A5
Paper feeders (CA02758-C75x) European/Asian spec USA spec Canadian spec	Feeder unit with/without a paper tray adjustable for a different size 0: No tray, 5: A4 size tray 1: No tray, 6: Letter size tray 2: No tray, 7: Letter size tray
Duplex unit (CA04040-C750) (CA04040-C751) (CA04040-C751)	Two-sided printing mechanism For Europe For USA For Canada

*1 When printing on Legal size paper at 600 dpi or printing large image data, we recommend the installation of additional memory cards of 10MB or more. (If you cannot get memory cards, select On for the banding mode in the FPS menu in menu mode using the control panel.)

Specifications

Specification	Description
Printing technology	Semiconductor laser + electrophotography
Emulations	Standard: Hewlett-Packard LaserJet 4 (PCL5e) PostScript level-2 compatible Switching: Automatic or by the control panel
Dimensions	Width: 376.5 mm (14.8 inches) Depth: 640 mm (25.2 inches) with MFF Height: 289 mm (11.4 inches) Weight: 18 kg (39.7 pounds) with MFF * MFF includes paper support wire.
Power requirements	120 VAC , 50 or 60 Hz (USA) 220 to 240 VAC , 50 or 60 Hz (Europe) Consumption: Maximum 600 W (full option) Average during operating 450 W or less 30 W or less during sleep mode
Environmental requirements	Temperature: 10° to 35°C (50° to 95°F) during operating 0° to 40°C (32° to 104°F) during storage Humidity: 20% to 80% relative humidity (non-condensing) during operating and storage Maximum wet bulb 29°C (84°F)
Acoustic noise	Sound pressure level (front, bystander position) Printing: 48 dBA without duplex unit 51 dBA with duplex unit Sleep mode: Background noise level Declared noise emissions in accordance with ISO9296 and ISO7779

Specifications

Specification	Description	
Safety and EMC certification or compliance	Safety: Models	Meets or complies with
	M3878SA14AV	UL 1950 CSA C22.2 No. 950 21 CFR 1040.10, Class I
	M3878SB14AV	EN 60950 EN 60825, Class 1
	EMC: Models	Meets or complies with
	M3878SA14AV	FCC Part 15B, Class B (Class A for Ethernet) DOC, Class B (Class A for Ethernet)
	M3878SB14AV	EN 55022, Class B (Class A for Ethernet) EN 50082-1
Performance	<p>Print resolution: 600 dots per inch</p> <p>Smoothing: Fujitsu advanced enhanced Imaging technology (FEIT) Equivalent to 1200 dpi</p> <p>Printing speed: For character printing on A4 size paper from first tray 10 or 14 pages per minute</p> <p>Warm-up time: At 25°C (77°F) 60 seconds or less</p> <p>Recommended duty cycle: 5000 pages per month (up to 35,000 pages per month)</p> <p>Toner bottle life: 5000 pages at 5% coverage continuous printing</p> <p>Print unit life: 30,000 pages at 5% coverage continuous printing</p>	

Specification	Description
Computer interface	<p>Standard: Parallel (Centronics), conforming to IEEE 1284 (Compatible and Nibble modes)</p> <p>Optional: Serial (RS-232C/422A) LocalTalk (AppleTalk compatible) Ethernet C (NetWare & TCP/IP corresponding)</p> <p>Switching: Automatic sensing</p>
Controller	<p>Processor: Fujitsu MB86936, 40 MHz</p> <p>RAM: 3 MB</p> <p>SIMM: 1, 2, 4, 8, 16, or 32 MB, 2 slots provided</p>
Fonts	<p>Resident: PCL mode</p> <p>46 fonts available</p> <p><i>Bitmapped</i></p> <p>Line Printer</p> <p><i>Scalable Intellifonts</i></p> <p>CG Times, Univers, Univers Condensed, Courier, Letter Gothic, Albertus, Antique Olive, Clarendon Condensed, Coronet, Garamond, Marigold, CG Omega</p> <p><i>Scalable TrueType</i></p> <p>Arial, Times New Roman, Symbol, Wingdings</p> <p>FPS mode</p> <p>35 fonts available</p> <p>Courier, Helvetica, Helvetica Narrow, Times, Symbol, Palatino, New Century Schoolbook, Avant Garde, Bookman, Zapf Chancery, Zapf Dingbats</p> <p>Soft fonts: Available from independent vendors</p>

SPECIFICATIONS

Specification		Description
Paper	<i>Type</i>	Single sheet photocopy paper (equivalent to Xerox 4024), bond paper, overhead transparencies (equivalent to 3M 731), and envelopes. See Chapter 3 for more information.
	<i>Size</i>	Tray: A4 (210 × 297 mm) A5 (148 × 210 mm) Letter (8.5 × 11 inches) Legal (8.5 × 14 inches) Executive (7.25 × 10.5 inches) Manual Minimum: feed slot 100 mm wide × 148 mm long and MFF: (3.94 × 5.81 inches) Maximum: 216 mm wide × 360 mm long (8.5 × 14.13 inches)
	<i>Weight</i>	60 to 90 g/m ² (16 to 24 pound bond) in tray 60 to 105 g/m ² (16 to 28 pound bond) in manual feed slot
	<i>Input</i>	Tray 1: 550 sheets of 0.09 mm thick paper Manual feed slot: 1 sheet Tray 2: 500 sheets of 0.09 mm thick paper (option) MFF: 100 sheets of 0.09 mm thick paper or 30 envelopes
	<i>Output</i>	Stacker: Face down (top cover) 250 sheets of 0.09 mm thick paper (possible to decrease depending on paper types and paper curl conditions) Rear stacker: Face up 20 sheets of 0.09 mm thick paper Rear stacker: Face up (duplex 20 sheets of 0.09 mm thick paper unit)

Glossary

Application software

A program that performs a particular task on a computer. Examples are word processing, spreadsheet, and database programs.

Baud

The speed of data transmission measured in bits per second. Baud rates apply to data transmission through the printer's serial interface. Baud is also called baud rate.

For example, 1200 baud is approximately equal to 120 characters per second.

Bit

A binary digit, or bit, is the smallest unit of information in a computer's memory. A bit can have the value 0 or 1, which represents the OFF and ON state in a computer's memory. Eight bits equals one byte.

Bit map

An image representation in which each point in the image is separately defined. For monochrome images, each point is defined by a single unit of information. For color images, each point is defined by several units of information, representing the different color elements.

The characters produced by a dot matrix printer are a kind of bit map. Each character image is created by defining the points in the dot matrix as either on or off.

Example:



Bitmapped font

A font in which the character images are defined by bit maps. With bitmapped fonts, a separate set of definitions is required for each point size. For example, Times 10 point and Times 12 point are considered separate fonts. *See also* Scalable font.

Configuration

A combination of settings that allows your computer and printer to work together. Some of the necessary settings are in the computer or application software, while other settings are in the printer. For example, the interface setting must be set the same in both the computer and the printer.

Corona wire

A fine wire in the printer that gives a positive charge to the paper. This charge causes the toner on the drum to transfer to the paper.

Default

A setting automatically used when you or your application software do not make a selection. The settings in effect when you turn on or reset the printer are called power-on defaults. *See also* Factory default.

Density

The darkness of the image as it appears on the page. If the density is too dark, the small white areas inside letters and numbers will be filled in. If the density is too light, pinholes appear in black areas. Print density can be adjusted with the print density dial.

Downloadable font

A font that is transferred (downloaded) to the printer's memory when or before it is needed. Before they are transferred, downloadable fonts are stored on font cards, floppy disks, or the computer's hard disk. Downloadable fonts are also called soft fonts.

Emulation

The ability of one printer to understand the command set of another printer. Emulations may be built into a printer's memory or may be supplied on optional plug-in emulation cards or cartridges.

Ethernet

A communication hardware for a high-speed network: developed by Xerox Corporation.

Factory default

The settings that are programmed into a printer at the factory. The printer uses these settings unless they are replaced by user selected settings entered from the control panel or through application software.

Flow control

See Serial protocol.

Font

A complete set of characters and symbols in one size, typeface, and style. Size refers to the character height, and is usually measured in points (1/72 inch). Typeface refers to the character design, such as Courier, Times, or Helvetica. Style refers to the character appearance, such as Italic or Bold. Typical examples of fonts are 12-point Courier Bold, and 10-point Times Italic.

Fuser unit

One of the internal parts of a page printer. The fuser unit bonds the toner to the paper. It consists of a heat roller and a pressure roller that the paper passes under after toner has been applied.

Hex dump

A special printout used for troubleshooting. A hex dump shows all data sent by the computer to the printer, including control characters. The data in a hex dump is expressed in hexadecimal format.

Initialization

Resets the printer to its power-on defaults. Initialization clears the print buffer of any data and places the printer online. *See also* Reset.

Interface

The means by which information is transferred from one part of a system to another. For example, the cable between the printer and the computer is an interface.

ISO symbol set

ISO stands for “International Organization for Standardization”. An ISO symbol set contains special international characters that replace the following twelve ASCII characters: #, \$, @, [, \,], ^, 9, {, |, }, and ~. ISO symbols sets are available for most European languages, Chinese, and Japanese.

LocalTalk

A protocol for an easy AppleTalk that connects devices and computers in a Macintosh system, developed by Apple Computer.

Margin

The space at the edges of a page in which no printing occurs. There are four margins: left, right, top, and bottom. In application software, margins are usually expressed in inches, centimeters, or points. In printer commands, left and right margins are specified as columns, while top and bottom margins are specified as lines.

Page printers have a minimum margin, typically of about .2 inch (5 mm), on all four sides, called the nonprint margin. No printing occurs in this margin. If the application software specifies a margin of 0, actual printing begins at the edge of the nonprint margin. *See also* Printable area.

MarkVision

A printer management integrated software which monitors printer status, displays optional printer’s features, spools print data, and cooperates with printer drivers. It also displays the virtual printer control panel to allow remote operation of printers.

Orientation

The direction of print on a page. Printing such that the shorter edges of the paper are at the top and bottom is called portrait orientation. Printing such that the longer edges of the paper are at the top and bottom is called landscape orientation.

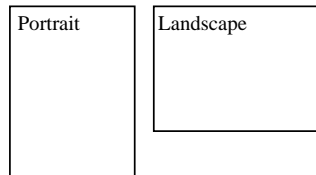
Example:**Page description language**

A set of codes that describe the placement of text and graphics on a page. Page Control Language (PCL), the language used by HP LaserJet printers, and Postscript are examples of page description languages.

Page protect

A printer feature that reserves a block of printer memory exclusively for text and graphics data. Page protect prevents memory overflow errors when printing very dense text or complex graphics. However, page protect also reduces the amount of printer memory available for downloadable fonts.

Parallel interface

A connection between the computer and printer in which data is transferred simultaneously through multiple wires. A parallel interface is faster than a serial interface, but the distance over which it can send data is limited. The Centronics interface is a type of parallel interface. *See also* Serial interface.

Photoconductive drum

The part inside a page printer on which the image is created before it is transferred to the paper.

Postscript

See Page description language.

Precharger wire

A fine wire in the printer's process cartridge that imparts an electrical charge to the photoconductive drum. The charge makes the drum sensitive to light.

Printable area

The area of the physical page in which the printer is able to print. Page printers have a nonprint margin, typically about .2 inch (5 mm) wide, at each edge of the paper. The printable area is the space within these margins. *See also* Margin.

Example:

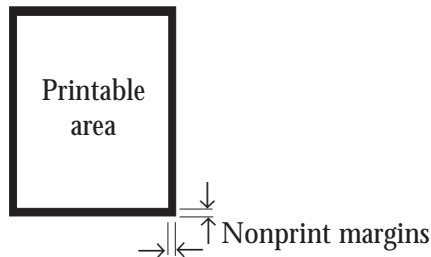

Printer driver

A set of instructions in application software that translates formatting choices into printer commands. When installing the application, the user identifies the type of printer being used so the application knows which printer driver to use.

Print unit

A maintenance package consisting of the photoconductive drum, developing unit, toner, and drum cleaner.

Reset

Clears the print buffer and places the printer online. Unlike initialization, reset leaves the currently selected settings in effect. That is, reset does not restore the power-on defaults. *See also* Initialization.

Resolution

The fineness of the printing. Resolution depends on the number of dots per inch. High resolution (with more dots) is finer and more precise than low resolution, which is coarser with rougher edges.

Scalable font

A font capable of printing in any point size. Scalable fonts are stored on the computer's hard disk. Each font consists of character templates that are used by the accompanying font utility software to create the characters in the desired point size.

Some font utilities create a complete set of characters in the desired size and send the complete set to the printer. Other utilities create and send only the individual characters as they are needed, which conserves printer memory.

Serial interface

A connection between the computer and printer in which data is transmitted sequentially over a single wire. A serial interface is slower than a parallel interface, but it can send data over a much greater distance. The RS-232C interface is a type of serial interface. *See also* Parallel interface.

Serial protocol

A set of rules used by the computer and the printer to regulate the flow of data between them.

Symbol set

The set of characters used in a font. Most symbol sets contain standard letters, numbers, and punctuation. Symbol sets differ in the accented characters, line drawing characters, and special symbols they contain. ASCII, Roman-8 and PC-8 and examples of symbol sets.

Symbol sets are also called character sets, which is the term usually used with dot matrix printer fonts. *See also* ASCII character set; ISO symbol set.

Toner

Electrically charged carbon particles that adhere to charged areas on the photoconductive drum to produce an image pattern. The carbon pattern is transferred to the paper and melted by the fuser unit to form a permanent image on the paper.

Transfer unit

The part inside a page printer that transfers the image from the photoconductive drum to the paper.

Index

A

AC power conditions 1-4 to 1-5
Accessories, ordering information B-1
Adjusting print density 1-27
AUTOEXEC.BAT file 4-7

B

Bitmapped fonts, resident
 available fonts C-3
 samples of A-1
Button functions 3-3 to 3-4

C

Cable, interface 1-17, 4-5, 4-8, 4-9
Cautionary notes
 electrostatic damage 1-5, 1-7, 1-18, 4-1,
 4-3, 4-5, 4-8, 4-9, 4-11, 5-1, 6-1
 paper jams 6-2
 printing off the physical page 3-31
 print unit
 exposing to light 1-7, 5-1
 removing protective sheets 1-7, 5-12
 touching drum 1-7, 5-12, 5-17
 turning upside down 5-9
 status report, interrupting printout of 3-6
Centronics interface
 See Parallel interface
Changing the paper tray size
 optional tray 4-12
 standard tray 3-25

Cleaner and cleaner pad 1-10, 5-5
Connecting power cord 1-16
Connecting printer to computer 1-17 to 1-19
CONT. button 3-4, 3-5
Control panel
 buttons 3-3 to 3-4
 indicators 3-2
Controller specifications C-2
Conventions used in this manual vi
Corona wire
 cleaning procedure 5-10
 when to clean 5-2, 6-10

D

Dark printout
 See Print density adjustment
DATA indicator 3-2
Density
 See Print density dial; Print quality problems
Double-side printing 3-32
Duplex unit 4-15

E

Emulation, selecting 1-20
ENTER button 3-4, 3-10, 3-11, 3-12, 3-13
Envelopes 3-24
Error indications 6-11 to 6-13
ERROR indicator 3-2
Ethernet interface 4-9

F

Factory defaults of PPMENU 2-4 to 2-5
Floppy disks, attached v
Font report 3-8 to 3-9
Font samples, resident A-1 to A-2

Font specifications C-3
FORM FEED button 3-4, 3-5
Front panel
 See Control panel
Fuser unit
 error condition 6-10
 when to replace 6-12

H

HP LaserJet 4 v
Humidity limitations 1-4, C-1

I

Indicators 3-2
Installation
 cleaner and cleaner pad 1-10
 interface boards 4-4 to 4-10
 multi-function feeder 1-15 to 1-16
 paper feeder 4-10
 print unit 1-7
 printer driver 1-21
 RAM card 4-1 to 4-3
 toner bottle 1-7
Interface
 Ethernet 4-9 to 4-10
 LocalTalk 4-7 to 4-8
 parallel 1-18
 serial 4-5 to 4-7
 types and merits 1-17, 1-18
Inventory of printer 1-6

L

Labels 3-25
Landscape orientation
 See Orientation: page
Language of message display 3-5
LaserJet 4
 See HP LaserJet 4

Letterhead 3-23, 3-32
Light printout
 See Print density adjustment
LocalTalk interface 4-7
Location of printer 1-4
Loading paper 1-12

M

Maintenance
 periodic routine 5-2 to 5-17
 cleaning corona wire 5-10
 cleaning paper path 5-10
 cleaning precharger wire 5-17
 replacing cleaner pad 5-5
 replacing print unit 5-7 to 5-16
 replacing toner bottle 5-2 to 5-5
 when to perform 5-2
 preventive 5-1
Manual feed
 selecting 3-10
 using 3-29 to 3-30
MarkVision
 installation 2-6
 operating environments vi
Memory expansion cards
 installation procedure 4-1 to 4-3
 ordering information B-1
MENU button 3-4, 3-5, 3-12
Menu mode
 functions 3-12 to 3-16
 items 3-16
 structure and how to use buttons 3-12
 submenus, items, options 3-13
Menu screen
 MarkVision 2-7
 PPMENU 2-3
Message display 3-3
Message language 3-5
MFF PAPER SIZE button 3-4, 3-11
Minus (-) button 3-4, 3-10, 3-11, 3-12, 3-13

MODE.COM file 4-7
 Multi-function feeder (MFF)
 installing 1-15 to 1-16
 selecting 3-10
 setting paper size 3-11

O

ONLINE indicator 3-2
 Operating environments vi
 Operational problems 6-8
 Options v
 Ordering information B-1 to B-2
 Orientation, page 3-32

P

Page orientation 3-32
 Paper
 feeding manually 3-29 to 3-30
 loading in tray 1-12 to 1-13
 maximum and minimum sizes 3-21
 printing on nonstandard sizes 3-31 to 3-32
 sizes and types 3-20 to 3-25
 specifications C-4
 Paper feeder 4-10
 Paper guide before corona wire, cleaning 5-11
 Paper jams
 avoiding 6-8
 clearing 6-1 to 6-7
 Paper margin 3-22
 Paper path
 cleaning procedure 5-10
 ordinary and straight 1-3
 when to clean 5-2, 6-10
 Paper size of MFF, setting 3-11
 Paper source, selecting 3-10
 Paper trays
 changing the paper tray size
 optional tray 4-12
 standard tray 3-25

 different size of 4-15
 loading paper 1-12 to 1-13
 ordering information B-2
 maximum number of sheets C-4
 selecting 3-10

Parallel interface 1-17 to 1-18

Parts of printer 1-1

Periodic routine maintenance 5-2 to 5-17

Plus (+) button 3-4, 3-10, 3-11, 3-12, 3-13

Portrait orientation

See Orientation: page

Power cord connection procedure 1-16 to 1-17

POWER indicator 3-2

PPMENU

 factory defaults 2-4 to 2-5

 installation 2-2

 operating environments vi

Precharger wire

 cleaning procedure 5-17

 when to clean 5-2, 6-10

Preprinted sheets 3-23

Preventive maintenance 5-1

Print density adjustment 1-27

Print density dial, when to adjust 6-10

PRINT FONT button 3-4, 3-8

Print parameter factory default settings
 (PPMENU)
 2-4 to 2-5

Print quality problems 6-9 to 6-11

Print unit

 cautionary notes

 exposing to light 1-7, 5-1

 removing protective sheets 5-12

 touching drum 1-7, 5-9, 5-12, 5-17

 turning upside down 5-9

 counter resetting 5-15

 installation procedure 1-7 to 1-9,
 5-12 to 5-14

 ordering information B-1

 procedure to remove 5-8 to 5-9

 when to replace 5-2, 6-10

Printer

- connecting to computer 1-17 to 1-18
- nomenclature 1-1 to 1-3
- operational problems 6-8
- repacking 5-18
- resetting 3-4, 3-6

Printer drivers

- control of print parameters by 2-1
- installation 1-21 to 1-25

Printer status indications 6-15**Printing**

- a test page offline 1-19
- feeding sheets manually 3-29 to 3-30
- on letterhead 3-23, 3-32
- on nonstandard size papers and envelopes 3-31
- on transparency material 3-23 to 3-24
- supported paper types and sizes 3-20 to 3-24, C-4

Printing a trial document with a printer driver 1-26**Printing area 3-22****Printing performance C-2****Problems**

- error indications 6-11 to 6-13
- operational 6-8
- paper jams 6-1 to 6-7
- print quality 6-9
- when printing a trial document 1-28

R**Ready, definition of 3-3****Rear stacker setting up 3-30****Repacking the printer 5-18****RESET button 3-4, 3-6****RESET MENU button 3-4, 3-12****Resetting**

- the print unit counter 5-15
- the printer 3-6

Resident fonts, samples of A-1 to A-2**RS-232C serial interface**

See Serial interface

S**Scalable fonts, resident**

- available fonts C-3
- samples of A-2

SELF TEST button 3-4, 3-6**Serial interface**

- how to connect 4-5 to 4-6
- parameter setting 4-6 to 4-7

Setting up

- printer in menu mode 3-12
- rear stacker 3-30

Specifications C-1 to C-4**Status indication 6-14, 6-15****Status report**

- Action required 6-15
- No action required 6-13

Supplies, ordering information B-1**T****Temperature limitations 1-4, C-1****Toner bottle**

- installation procedure 1-7 to 1-9
- ordering information B-1
- replacement procedure 5-2 to 5-5

Transparencies 3-23**TRAY SELECT button 3-4, 3-10****Two-sided printing 3-32****W****Warning messages 6-16**

Fujitsu Offices

Please send your comments on this manual or on Fujitsu products to the following addresses:

FUJITSU COMPUTER PRODUCTS OF AMERICA, INC.
2904 Orchard Parkway, San Jose
CA 95134-2022, U.S.A.
TEL: (1-408) 432-6333
FAX: (1-408) 894-1709

FUJITSU CANADA INC.
2800 Matheson Boulevard East
Mississauga, Ontario L4W 4X5, CANADA
TEL: (1-905) 602-5454
FAX: (1-905) 602-5457

FUJITSU AUSTRALIA LIMITED
475 Victoria Avenue, Chatswood
N.S.W., 2067, AUSTRALIA
TEL: (61-2) 410-4555
FAX: (61-2) 411-8603

FUJITSU DEUTSCHLAND GmbH.
Frankfurter Ring 211
80807, München, F.R. GERMANY
TEL: (49-89) 32378-0
FAX: (49-89) 32378-100

FUJITSU ESPAÑA, S.A.
Almagro 40, 28009 Madrid, SPAIN
TEL: (34-1) 581-8400
FAX: (34-1) 581-8125

FUJITSU EUROPE LTD.
2 Longwalk Road, Stockly Park, Uxbridge
Middlesex UB11 1AB, ENGLAND
TEL: (44-81) 573-4444
FAX: (44-81) 573-2643

FUJITSU FRANCE S.A.
1, place des Etats-Unis Silic 310
94588 RUNGIS Cedex, FRANCE
TEL: (33-1) 41-80-38-80
FAX: (33-1) 41-80-38-66

FUJITSU HONG KONG LIMITED
Room 2521, Sun Hung Kai Centre
30 Harbour Road, HONG KONG
TEL: (852) 827-5780
FAX: (852) 827-4724

FUJITSU ICIM LTD.
Nagar Road, Pune 411 014, INDIA
TEL: (91-212) 681-528
FAX: (91-212) 680-238

FUJITSU ITALIA S.p.A.
Via Nazario Sauro, 38
20099 Sesto S. Giovanni (MI), ITALY
TEL: (39-2) 26294-1
FAX: (39-2) 26294-201

FUJITSU KOREA LTD.
9th Floor, Korean Reinsurance Bldg.
80, Susong-Dong, Chongro-Gu
Seoul Special City, Republic of KOREA
TEL: (82-2) 739-3281
FAX: (82-2) 739-3294

FUJITSU NORDIC AB
Kung Hans Väg 12
S-191 76 Sollentuna, SWEDEN
TEL: (46-8) 626-6000
FAX: (46-8) 626-6711

FUJITSU (SINGAPORE) PTE. LTD.
75 Science Park Drive
#02-06 CINTECH II, SINGAPORE 0511
TEL: (65) 777-6577
FAX: (65) 777-8794

FUJITSU SYSTEMS BUSINESS (MALAYSIA) SDN. BHD.
Fujitsu Plaza, 1A, Jalan Tandang 204
P.O. Box 636 Pejabat Pos Jalan Sultan
46770 Petaling Jaya
Selangor Darul Ehsan, MALAYSIA
TEL: (60-3) 793-3888
FAX: (60-3) 793-0888

FUJITSU SYSTEMS BUSINESS (THAILAND) LTD.
12th Floor, Olympia Thai Tower
444 Rachadapisek Road, Samsenok
Huaykwang, Bangkok 10310, THAILAND
TEL: (662) 512-6066
FAX: (662) 512-6068

FUJITSU TAIWAN LTD.
8th FL., NO. 170, Hung Tai Center
Tun Hwa N. RD., Taipei, TAIWAN, R.O.C.
TEL: (886-2) 545-7700
FAX: (886-2) 717-4644

FUJITSU LIMITED
Computer Products Business Group
Kamikodanaka 4-1-1, Nakahara-ku
Kawasaki-shi 211, JAPAN
TEL: (81-44) 754-8633
FAX: (81-44) 754-8510